

# NUMERIC and HEXADECIMAL INDICATORS

## 5082-7300 SERIES

TENTATIVE DATA MAY 1972

### FEATURES

- Numeric 5082-7300/-7302
  - 0-9, Test State, Minus Sign, Blank States
  - Decimal Point
  - 7300 Right Hand D.P.
  - 7302 Left Hand D.P.
- Hexadecimal 5082-7340
  - 0-9, A-F, Base 16 Operation
  - Blanking Control, Conserves Power
  - No Decimal Point
- DTL – TTL Compatible
- Includes Decoder/Driver with Memory
  - 8421 Positive Logic Input
- 4 X 7 Dot Matrix Array
  - Shaped Character, Excellent Readability
- Standard .600 inch X .400 inch Dual-in-Line Package including Contrast Filter
- Categorized for Luminous Intensity
  - Assures Uniformity of Light Output from Unit to Unit within a Single Category

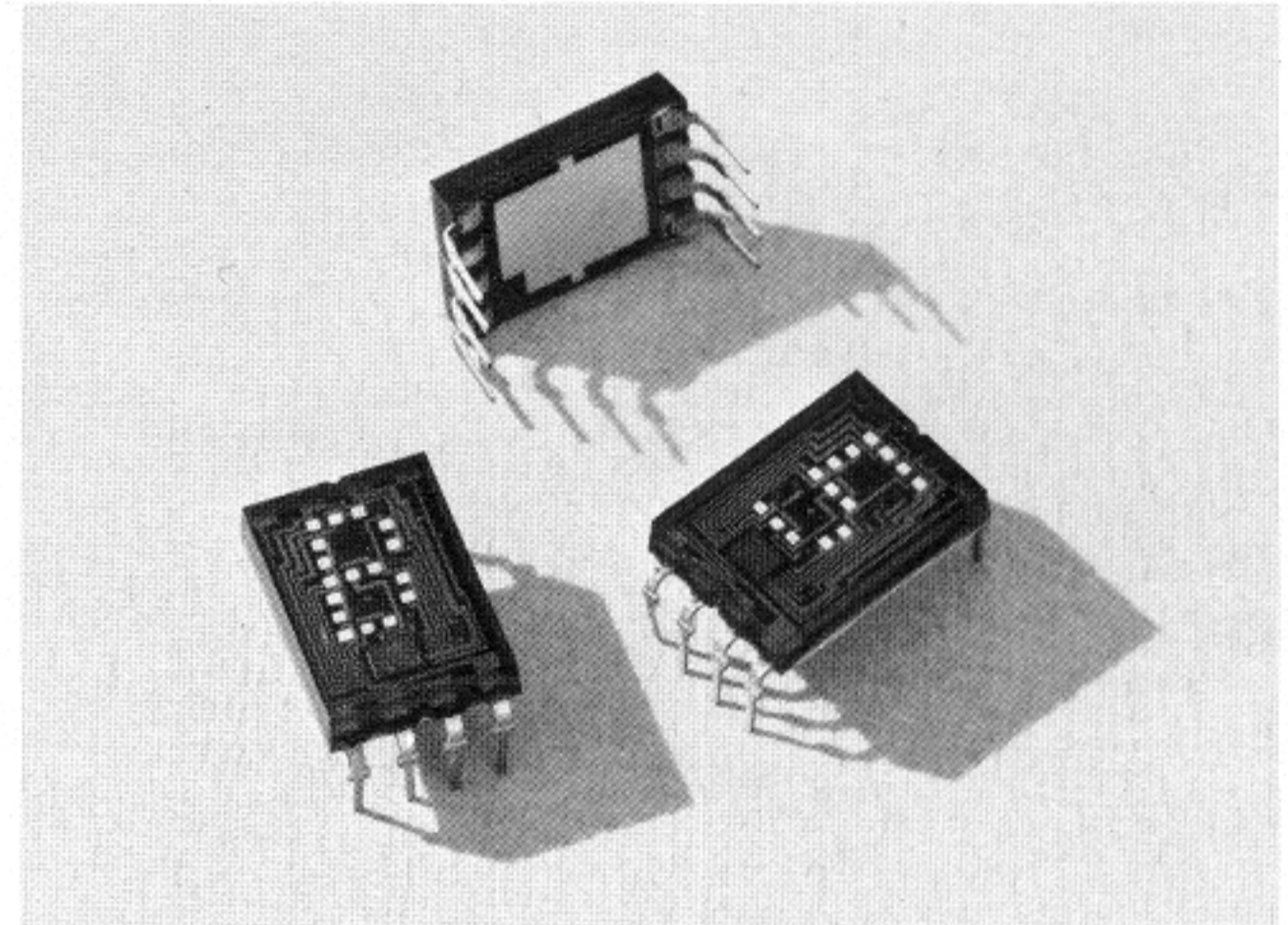

### DESCRIPTION

The HP 5082-7300 series solid state numeric and hexadecimal indicators with on-board decoder/driver and memory provide a reliable, low-cost method for displaying digital information.

The 5082-7300 numeric indicator decodes positive 8421 BCD logic inputs into characters 0-9, a "-" sign, a test pattern, and four blanks in the invalid BCD states. The unit employs a right-hand decimal point. Typical applications include point-of-sale terminals, instrumentation, and computer systems.

The 5082-7302 is the same as the 5082-7300, except that the decimal point is located on the left-hand side of the digit.

The 5082-7340 hexadecimal indicator decodes positive 8421 logic inputs into 16 states, 0-9 and A-F. In place of the decimal point an input is provided for blanking the display (all LED's off), without losing the contents of the memory. Applications include terminals and computer systems using the base-16 character set.

The 5082-7304 is a "±1" overrange character, including decimal point, used in instrumentation applications.

### PACKAGE DIMENSIONS

#### FRONT VIEW

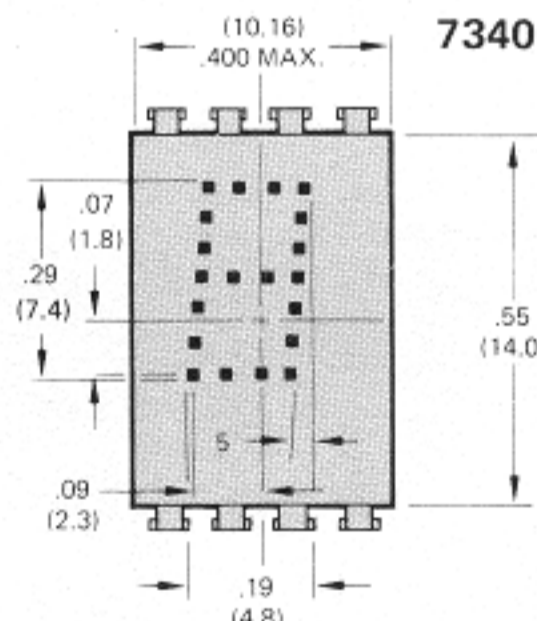
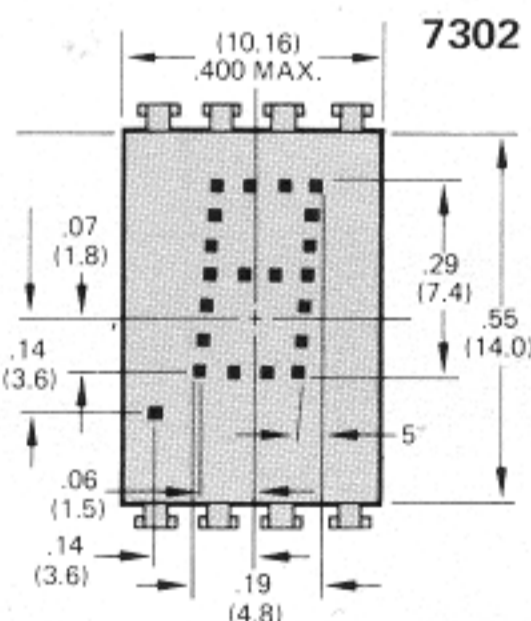
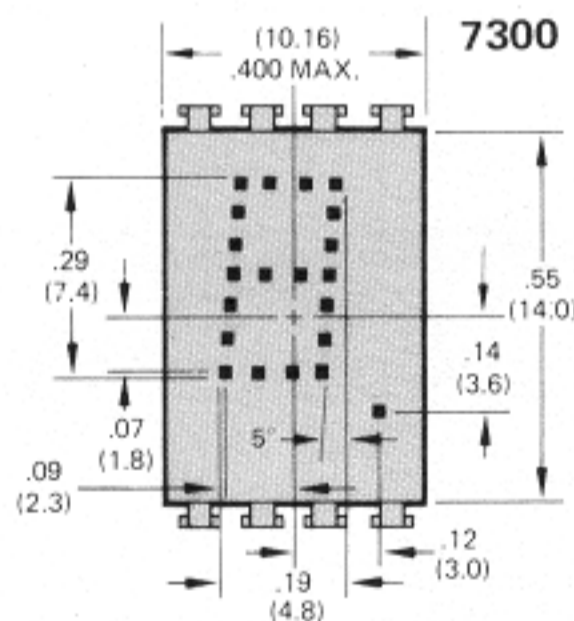

#### REAR VIEW

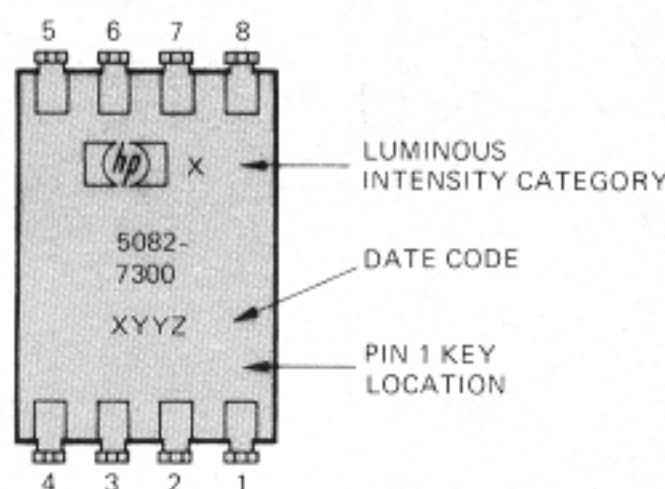

#### SIDE VIEW

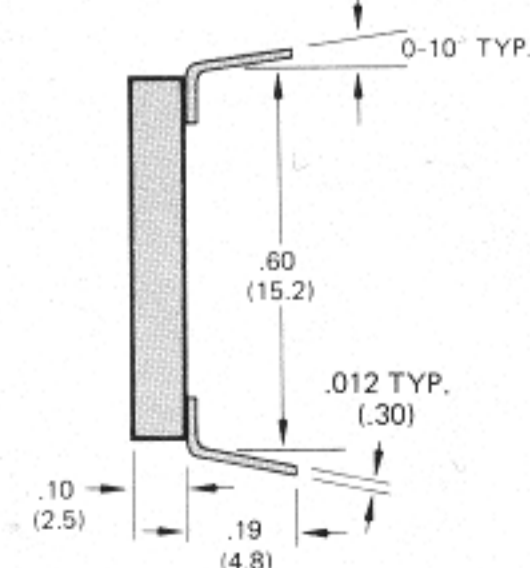

#### END VIEW

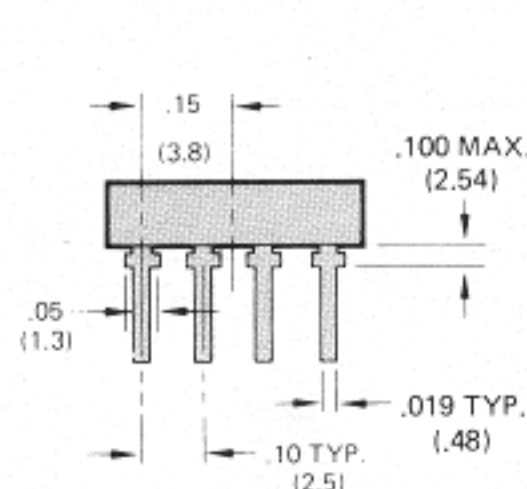

PIN	FUNCTION	
	5082-7300 and 7302 Numeric	5082-7340 Hexadecimal
1	Input 2	Input 2
2	Input 4	Input 4
3	Input 8	Input 8
4	Decimal point	Blanking control
5	Latch enable	Latch enable
6	Ground	Ground
7	V <sub>cc</sub>	V <sub>cc</sub>
8	Input 1	Input 1

- NOTES: 1. Dimensions in inches and (millimeters).  
2. Unless otherwise specified, the tolerance on all dimensions is ±.015 inches.

## ABSOLUTE MAXIMUM RATINGS

DESCRIPTION	SYMBOL	MIN	MAX	UNIT
Storage temperature, ambient	$T_S$	-40	+100	$^{\circ}\text{C}$
Operating temperature, case	$T_C$	-20	+85	$^{\circ}\text{C}$
$V_{CC}$ Pin potential to ground pin	$V_{CC}$	-0.5	+7.0	V
Voltage applied to input logic pins and decimal point (1)	$V_{in}$	-0.5	+5.5	V
Voltage applied to latch enable	$V_E$	-0.5	+5.5	V
Voltage applied to blanking control (2)	$V_B$	-0.5	+5.5	V

NOTES: 1. Decimal point applies only to 7300/7302 2. Applies only to 7340

## RECOMMENDED OPERATING CONDITIONS

DESCRIPTION	SYMBOL	MIN	NOM	MAX	UNIT
Supply Voltage	$V_{CC}$	4.5	5.0	5.5	V
Logic voltage "0" state	$V_{in(0)}$	0		0.8	V
Logic voltage "1" state	$V_{in(1)}$	2.0		5.25	V
Latch enable voltage—data being entered	$V_E(0)$	0		0.8	V
Latch enable voltage—data not being entered	$V_E(1)$	2.0		5.25	V
Blanking control voltage—display not blanked (1)	$V_B(0)$	0		0.8	V
Blanking control voltage—display blanked (1)	$V_B(1)$	3.5		5.25	V

NOTE: 1. Applies only to 7340

## ELECTRICAL/OPTICAL CHARACTERISTICS ( $T_C = -20^{\circ}\text{C}$ to $+85^{\circ}\text{C}$ , unless otherwise specified)

DESCRIPTION	SYMBOL	TEST CONDITIONS	MIN	TYP	MAX	UNIT
Supply current	$I_{CC}$	$V_{CC} = 5.5\text{V}$		94(1)	170(2)	ma
Power dissipation	$P_T$	$V_{CC} = 5.5\text{V}$		470(1)	935(2)	mW
Luminous intensity per LED (Digit average) (3)	$I$	$V_{CC} = 5.0\text{V}, T_C = 25^{\circ}\text{C}$	32	70		$\mu\text{cd}$
Time data must be presented to logic input prior to enable rising	$t_{\text{setup}}$	$V_{CC} = 5.0\text{V}, V_E(0) = 0.4\text{V}$ $V_{in(0)} = 0.4\text{V}, V_E(1) = 2.4\text{V}$ $V_{in(1)} = 2.4\text{V}, T_C = 25^{\circ}\text{C}$		30	50	ns
Time data must be held after enable rises	$t_{\text{hold}}$	$V_{CC} = 5.0\text{V}, V_E(0) = 0.4\text{V}$ $V_{in(0)} = 0.4\text{V}, V_E(1) = 2.4\text{V}$ $V_{in(1)} = 2.4\text{V}, T_C = 25^{\circ}\text{C}$		30	50	ns
Time required for 90% change in display luminous intensity after change of state of $V_B$ (4)	$t_{\text{blank}}$	$V_{CC} = 5.0\text{V}, T_C = 25^{\circ}\text{C}$			500	ns
Blanking control current "0" state (4)	$I_B(0)$	$V_{CC} = 5.5\text{V}, V_B(0) = 0.8\text{V}$			200	$\mu\text{A}$
Blanking control current "1" state (4)	$I_B(1)$	$V_{CC} = 5.5\text{V}, V_B(1) = 4.5\text{V}$			2.0	mA
Logic and latch enable currents "0" state	$I_{in(0)}, I_E(0)$	$V_{CC} = 5.5\text{V}$ $V_{in}, V_E = 0.4\text{V}$			-1.6	mA
Logic and latch enable currents "1" state	$I_{in(1)}, I_E(1)$	$V_{CC} = 5.5\text{V}$ $V_{in}, V_E = 2.4\text{V}$			+250	$\mu\text{A}$
Peak wavelength	$\lambda_{\text{peak}}$			655		nm
Spectral halfwidth	$\Delta\lambda_{1/2}$			30		nm
Weight				0.8		gm

### NOTES:

- $V_{CC} = 5.0\text{V}$  with statistical average number of LED's lit.
- Worst case condition excluding test state on 5082-7300/-7302.
- The digits are categorized for luminous intensity such that the variation from digit to digit within a category is not discernible to the eye. Intensity categories are designated by a letter located on the reverse side of the package contiguous with the Hewlett-Packard logo marking.
- Applies only to 7340.

CHARACTER		INPUTS						CHARACTER		INPUTS					
5082-7300/7302 Numeric	5082-7340 Hex.	X8	X4	X2	X1	E	B <sup>(1)</sup>	5082-7300/7302 NUMERIC	5082-7340 Hex.	X8	X4	X2	X1	E	B <sup>(1)</sup>
0	0	L	L	L	L	L	L	Test	A	H	L	H	L	L	L
1	1	L	L	L	H	L	L	Blank	B	H	L	H	H	L	L
2	2	L	L	H	L	L	L	Blank	C	H	H	L	L	L	L
3	3	L	L	H	H	L	L	Minus	D	H	H	L	H	L	L
4	4	L	H	L	L	L	L	Blank	E	H	H	H	L	L	L
5	5	L	H	L	H	L	L	Blank	F	H	H	H	H	L	L
6	6	L	H	H	L	L	L	Hold	Hold	d	d	d	d	H	d
7	7	L	H	H	H	L	L	—	Blank (1)	d	d	d	d	d	H
8	8	H	L	L	L	L	L	Decimal pt. on (2)	—	DP <sub>in</sub> = L					
9	9	H	L	L	H	L	L	Decimal pt. off (2)	—	DP <sub>in</sub> = H					

**NOTES:**

1. The blanking control input, B, pertains to the 5082-7340 Hexadecimal Indicator only.
2. The decimal point input pertains to the 5082-7300 and -7302 Numeric Indicators only.

Figure 1. Truth Table for 5082-7300 Series Devices

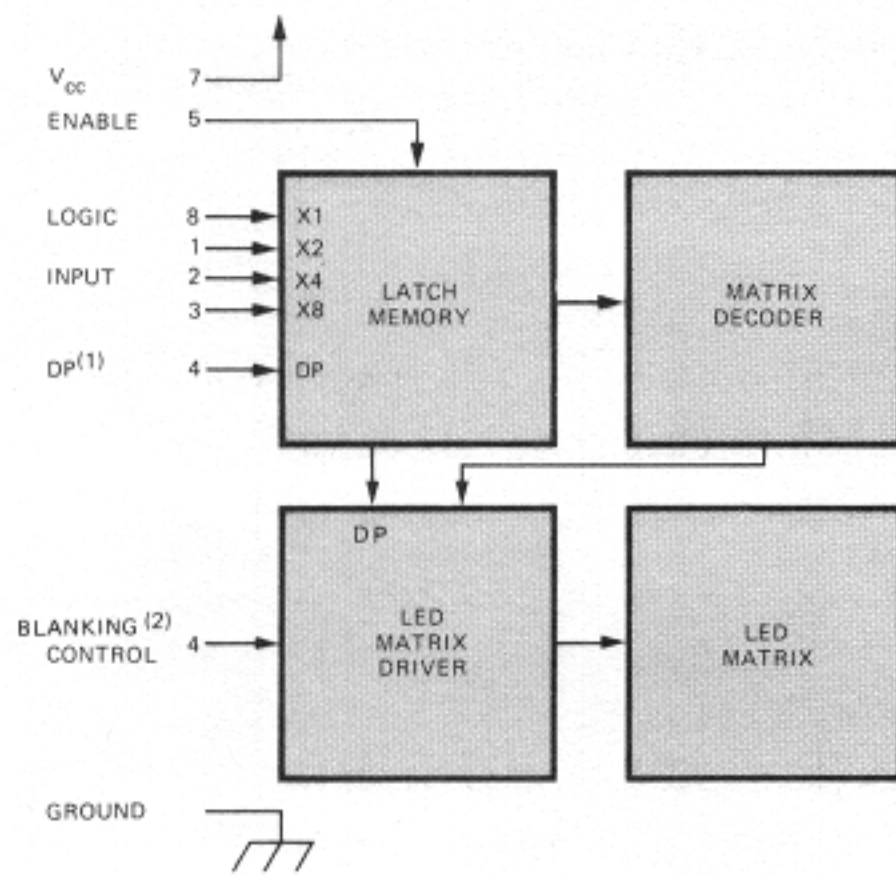

- Notes 1. 5082 - 7300/-7302 only  
2. 5082 - 7340 only

Figure 2. Block Diagram of 5082-7300 Series Logic.

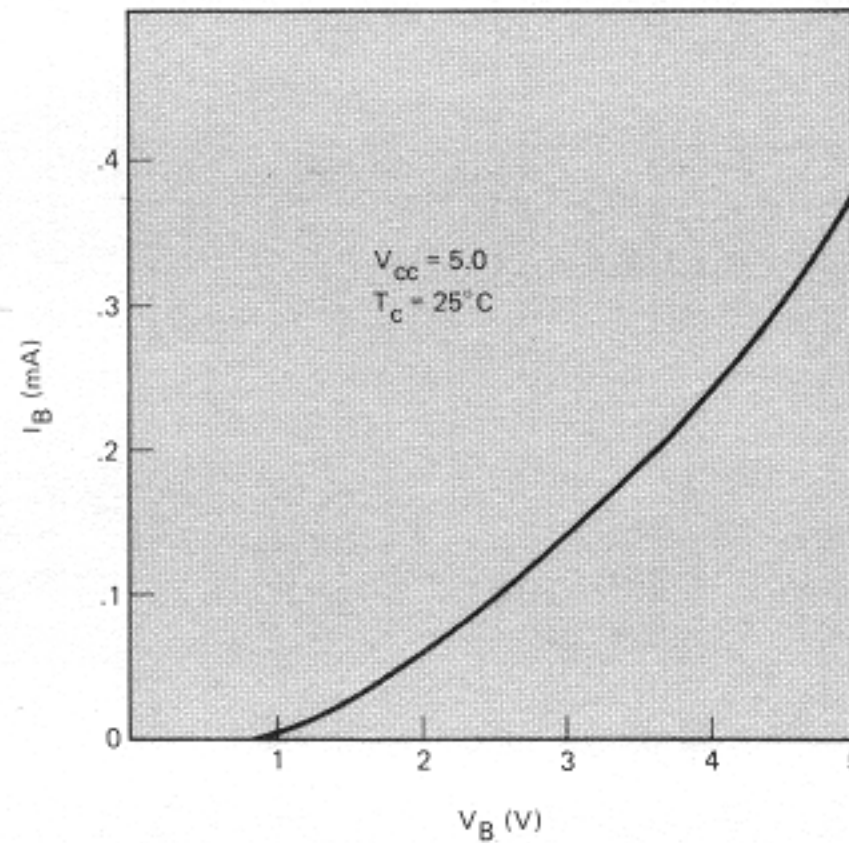

Figure 3. Typical Blanking Control Current Vs. Voltage for 5082-7340 Only.

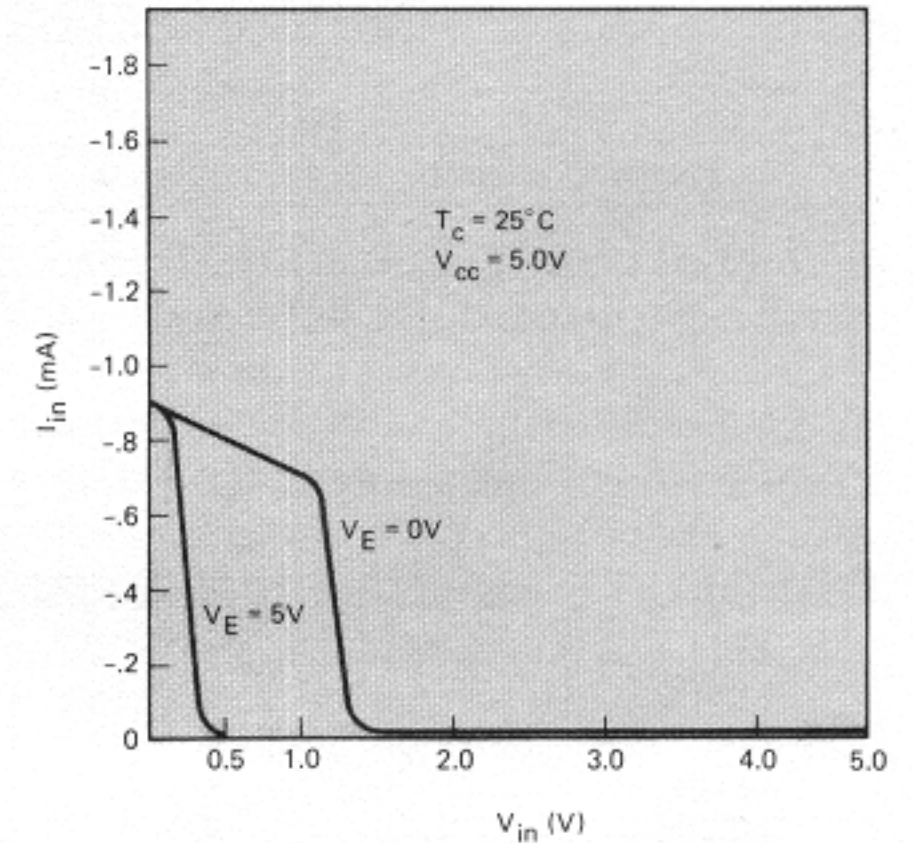

Figure 4. Typical Logic and Decimal Point Input Current Vs. Voltage for the 5082-7300 Series Devices. Decimal Point Applies to 5082-7300 Only.

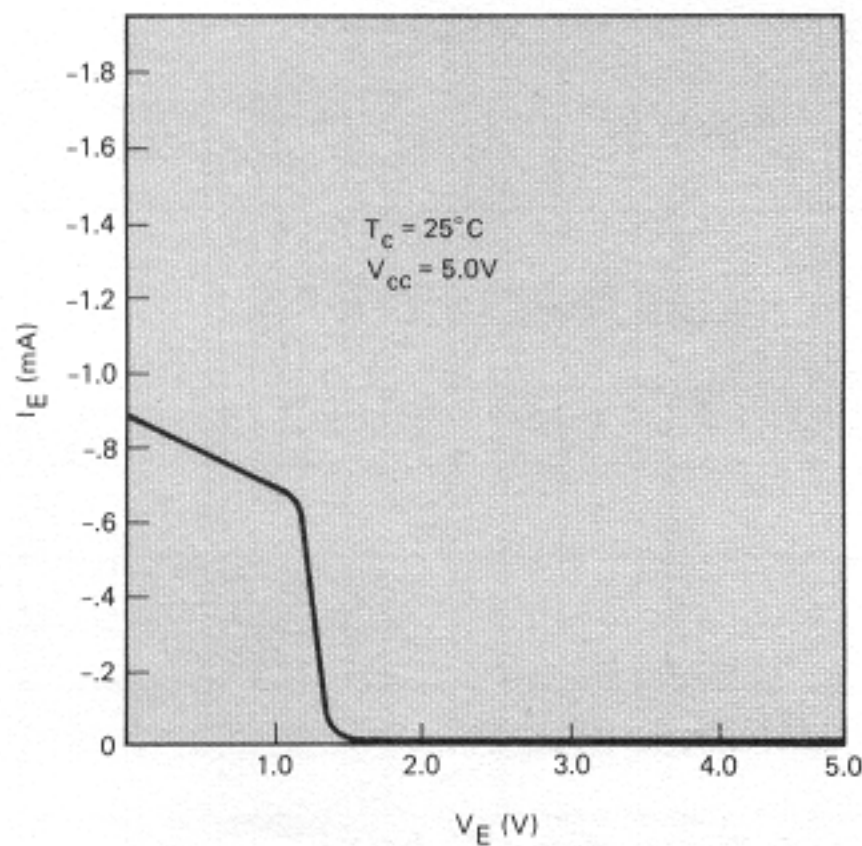

Figure 5. Typical Latch Enable Input Current Vs. Voltage for the 5082-7300 Series Devices.

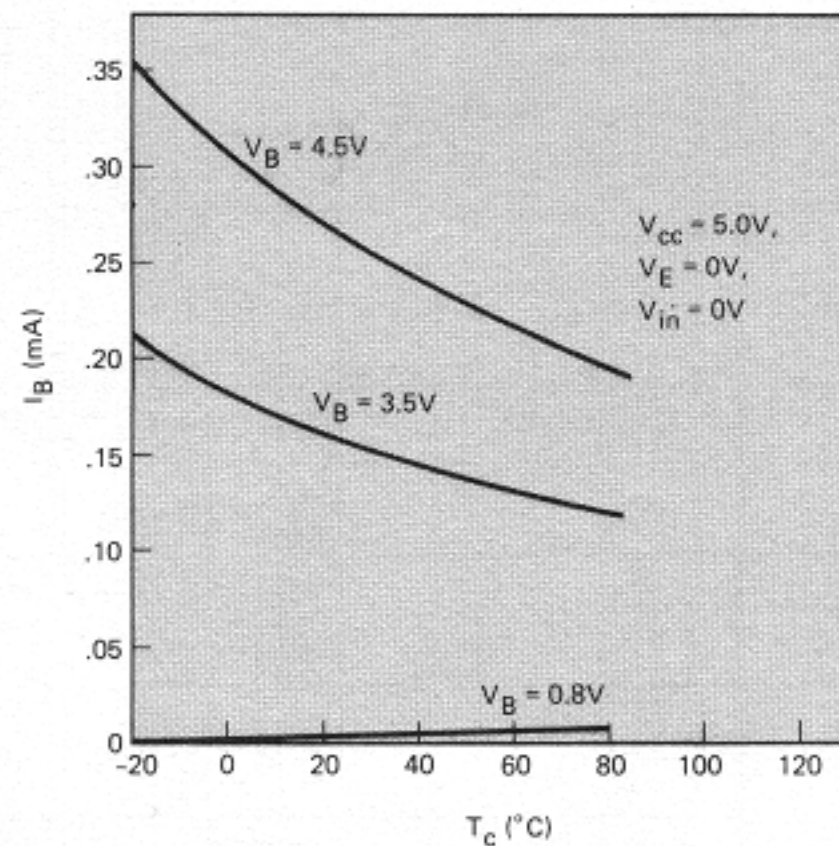

Figure 6. Typical Blanking Control Input Current Vs. Temperature, 5082-7340.

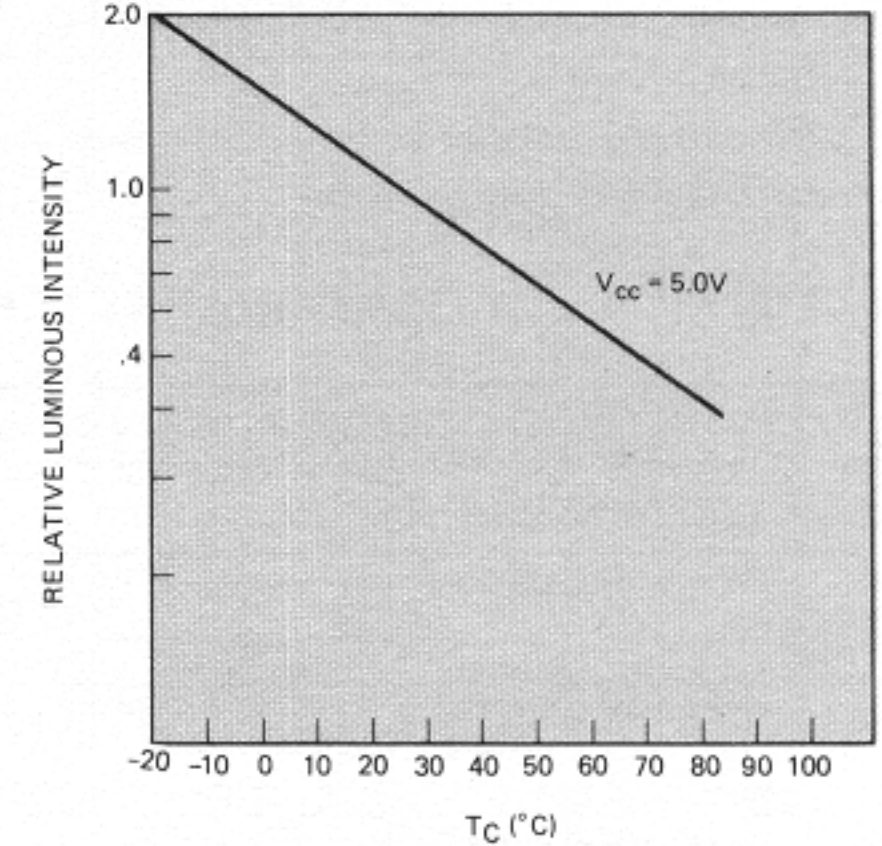
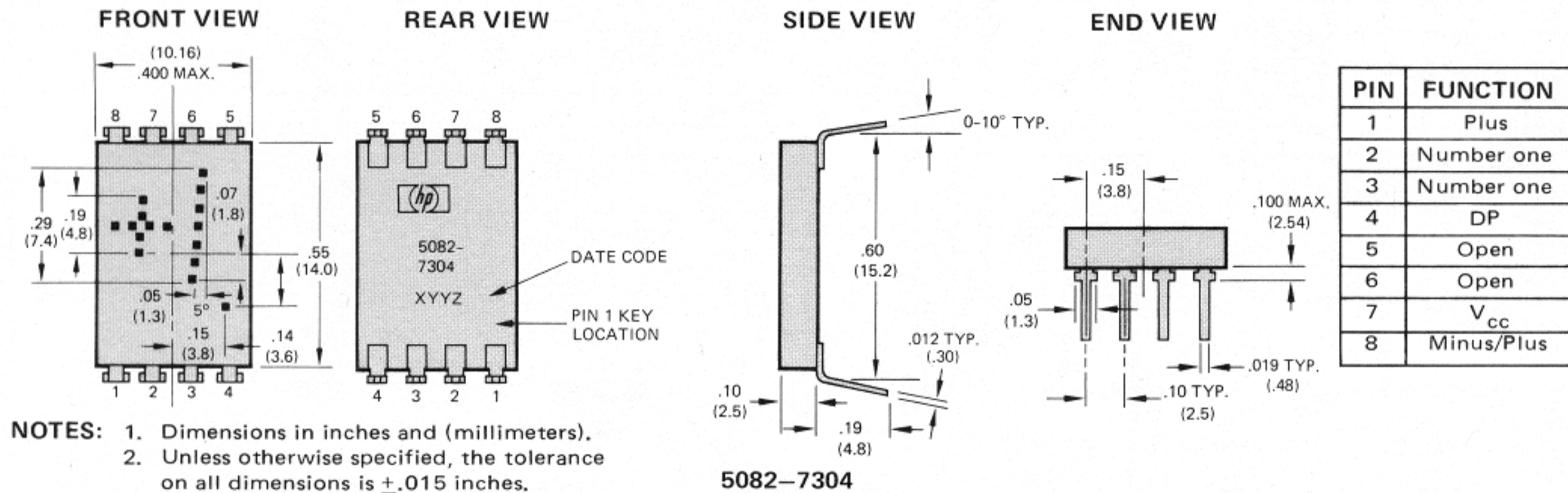

Figure 7. Typical Luminous Intensity Vs. Case Temperature for the 5082-7300 Series Devices.

## SOLID STATE PLUS/MINUS/ONE SIGN

For display applications requiring a  $\pm$  or 1 designation, the 5082-7304 plus/minus/one sign including decimal point is available. This display module comes in the same package as the 5082-7300 series numeric indicator and is completely compatible with it.



CHARACTER	PIN			
	1	2,3	4	8
+	1	0	0	1
-	0	0	0	1
1	0	1	0	0
Decimal point	0	0	1	0
Blank	0	0	0	0

**NOTE:** 0: Line switching transistor in Fig. 11 cutoff  
1: Line switching transistor in Fig. 11 saturated

Figure 8. Truth table for 5082-7304

## ABSOLUTE MAXIMUM RATINGS

DESCRIPTION	SYMBOL	MIN	MAX	UNIT
Storage temperature, ambient	T <sub>s</sub>	-40	+100	°C
Operating temperature, case	T <sub>C</sub>	-20	+85	C
Forward current, each LED	I <sub>F</sub>		10	mA
Reverse voltage, each LED	V <sub>R</sub>		4	V

## RECOMMENDED OPERATING CONDITIONS

	SYMBOL	MIN	NOM	MAX	UNIT
LED supply voltage	V <sub>CC</sub>	4.5	5.0	5.5	V
Forward current, each LED	I <sub>F</sub>		5.0	10	mA

**NOTE:**

LED current must be externally limited. Refer to Figure 11 for recommended resistor values.

## ELECTRICAL/OPTICAL CHARACTERISTICS (T<sub>C</sub> = -20°C TO +85°C, UNLESS OTHERWISE SPECIFIED)

DESCRIPTION	SYMBOL	TEST CONDITIONS	MIN	TYP	MAX	UNIT
LED forward voltage	V <sub>F</sub>	I <sub>F</sub> = 10 mA		1.6	2.0	V
Power dissipation	P <sub>T</sub>	I <sub>F</sub> = 10 mA all diodes lit		250	320	mW
Luminous intensity per LED (DIGIT average)	I	I <sub>F</sub> = 6 mA T <sub>C</sub> = 25°C	32	70		μcd
Peak wavelength	λ <sub>peak</sub>			655		nm
Spectral halfwidth	Δλ <sub>1/2</sub>			30		nm
Weight				0.8		gm

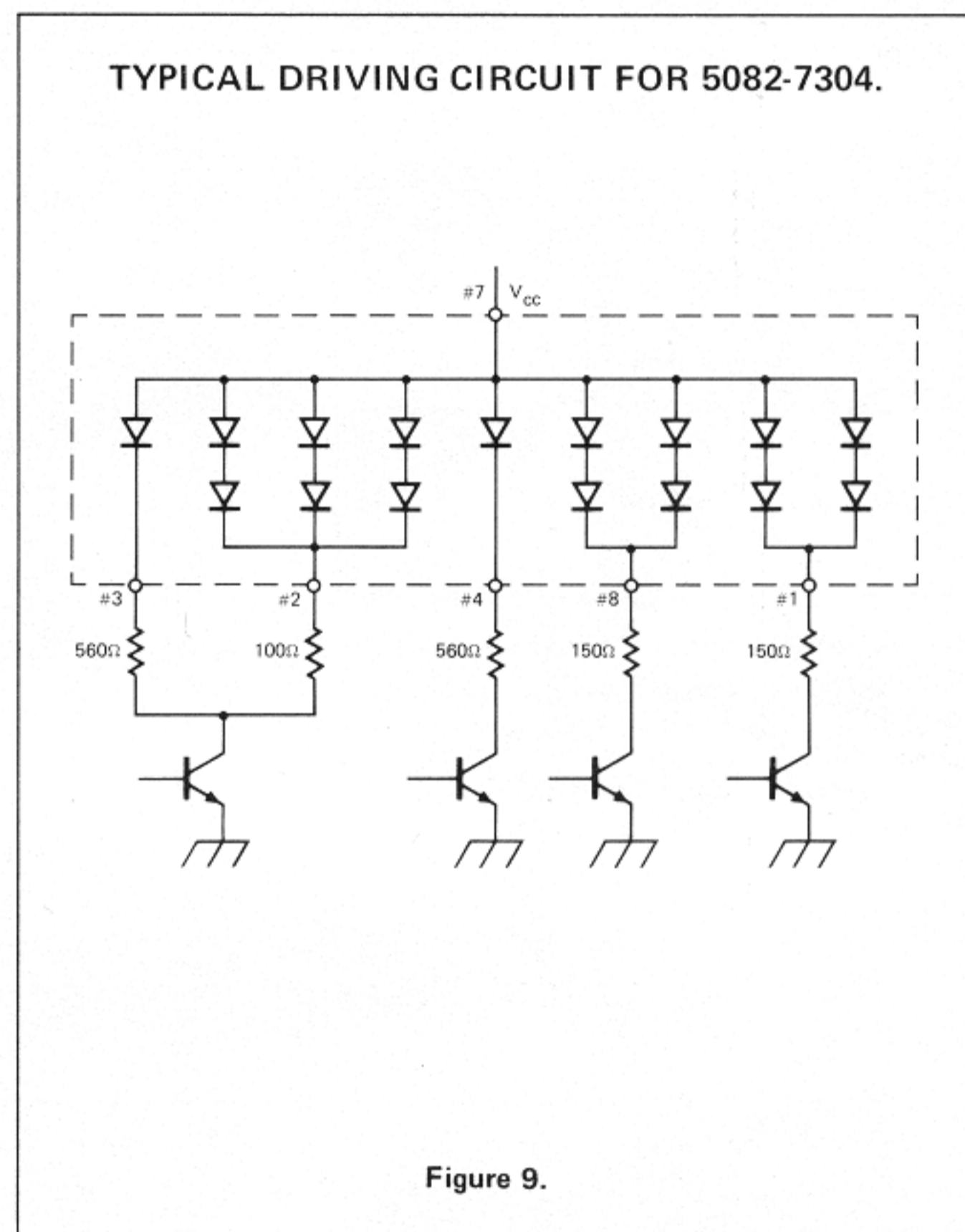

For further information concerning electrical and mechanical implementation of the 5082-7300 series devices, please refer to Application Note 934.

For more information, call your local HP Sales Office or East (201) 265-5000 • Midwest (312) 677-0400 • South (404) 436-6181  
West (213) 877-1282. Or, write: Hewlett-Packard, 1501 Page Mill Road, Palo Alto, California 94304. In Europe, 1217 Meyrin-Geneva  
Printed In U.S.A.