

---

# HM5164165F Series

# HM5165165F Series

64M EDO DRAM (4-Mword × 16-bit)  
8k refresh/4k refresh

# HITACHI

ADE-203-1058B(Z)  
Rev. 2.0  
Nov. 30, 1999

---

## Description

The Hitachi HM5164165F Series, HM5165165F Series are 64M-bit dynamic RAMs organized as 4,194,304-word × 16-bit. They have realized high performance and low power by employing CMOS process technology. HM5164165F Series, HM5165165F Series offer Extended Data Out (EDO) Page Mode as a high speed access mode. They have the package variations of standard 50-pin plastic SOJ and standard 50-pin plastic TSOPII

## Features

- Single 3.3 V supply: 3.3 V ± 0.3 V
- Access time: 50 ns/60 ns (max)
- Power dissipation
  - Active: 432 mW/396 mW (max) (HM5164165F Series)  
: 504 mW/432 mW (max) (HM5165165F Series)
  - Standby : 1.8 mW (max) (CMOS interface)  
: 1.1 mW (max) (L-version)
- EDO page mode capability
- Refresh cycles
  - $\overline{\text{RAS}}$ -only refresh  
8192 cycles/64 ms (HM5164165F, HM5164165FL)  
4096 cycles/64 ms (HM5165165F, HM5165165FL)
  - CBR/Hidden refresh  
4096 cycles/64 ms (HM5164165F, HM5164165FL, HM5165165F, HM5165165FL)

---

## HM5164165F Series, HM5165165F Series

---

- 4 variations of refresh
  - $\overline{\text{RAS}}$ -only refresh
  - $\overline{\text{CAS}}$ -before- $\overline{\text{RAS}}$  refresh
  - Hidden refresh
  - Self refresh (L-version)
- $2\overline{\text{CAS}}$ -byte control
- Battery backup operation (L-version)

### Ordering Information

Type No.	Access time	Package
HM5164165FJ-5	50 ns	400-mil 50-pin plastic SOJ (CP-50DA)
HM5164165FJ-6	60 ns	
HM5164165FLJ-5	50 ns	
HM5164165FLJ-6	60 ns	
HM5165165FJ-5	50 ns	
HM5165165FJ-6	60 ns	
HM5165165FLJ-5	50 ns	
HM5165165FLJ-6	60 ns	
HM5164165FTT-5	50 ns	400-mil 50-pin plastic TSOP II (TTP-50DB)
HM5164165FTT-6	60 ns	
HM5164165FLT-5	50 ns	
HM5164165FLT-6	60 ns	
HM5165165FTT-5	50 ns	
HM5165165FTT-6	60 ns	
HM5165165FLT-5	50 ns	
HM5165165FLT-6	60 ns	

---



## Pin Arrangement (HM5165165F Series)

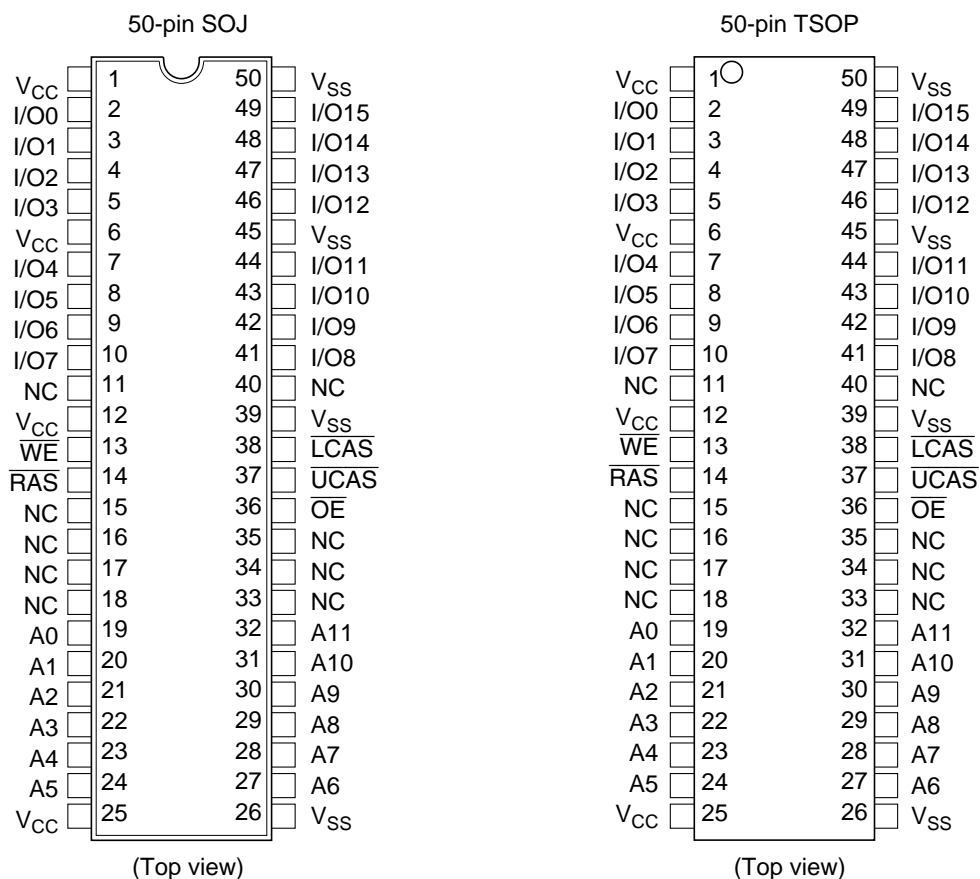

## Pin Description

Pin name	Function
A0 to A11	Address input — Row/Refresh address A0 to A11 — Column address A0 to A9
I/O0 to I/O15	Data input/output
$\overline{\text{RAS}}$	Row address strobe
$\overline{\text{UCAS}}$ , $\overline{\text{LCAS}}$	Column address strobe
$\overline{\text{WE}}$	Write enable
$\overline{\text{OE}}$	Output enable
V <sub>CC</sub>	Power supply
V <sub>SS</sub>	Ground
NC	No connection

Block Diagram (HM5164165F Series)

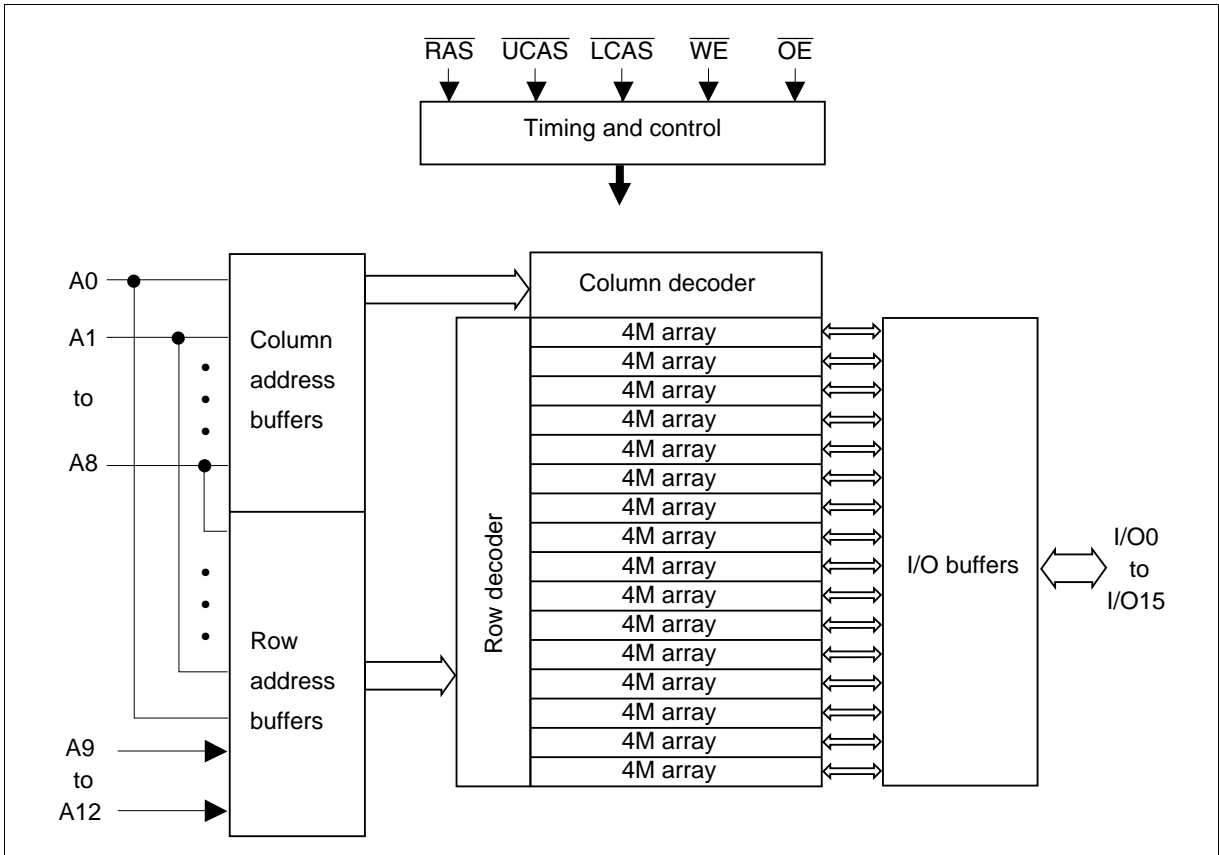

## Block Diagram (HM5165165F Series)

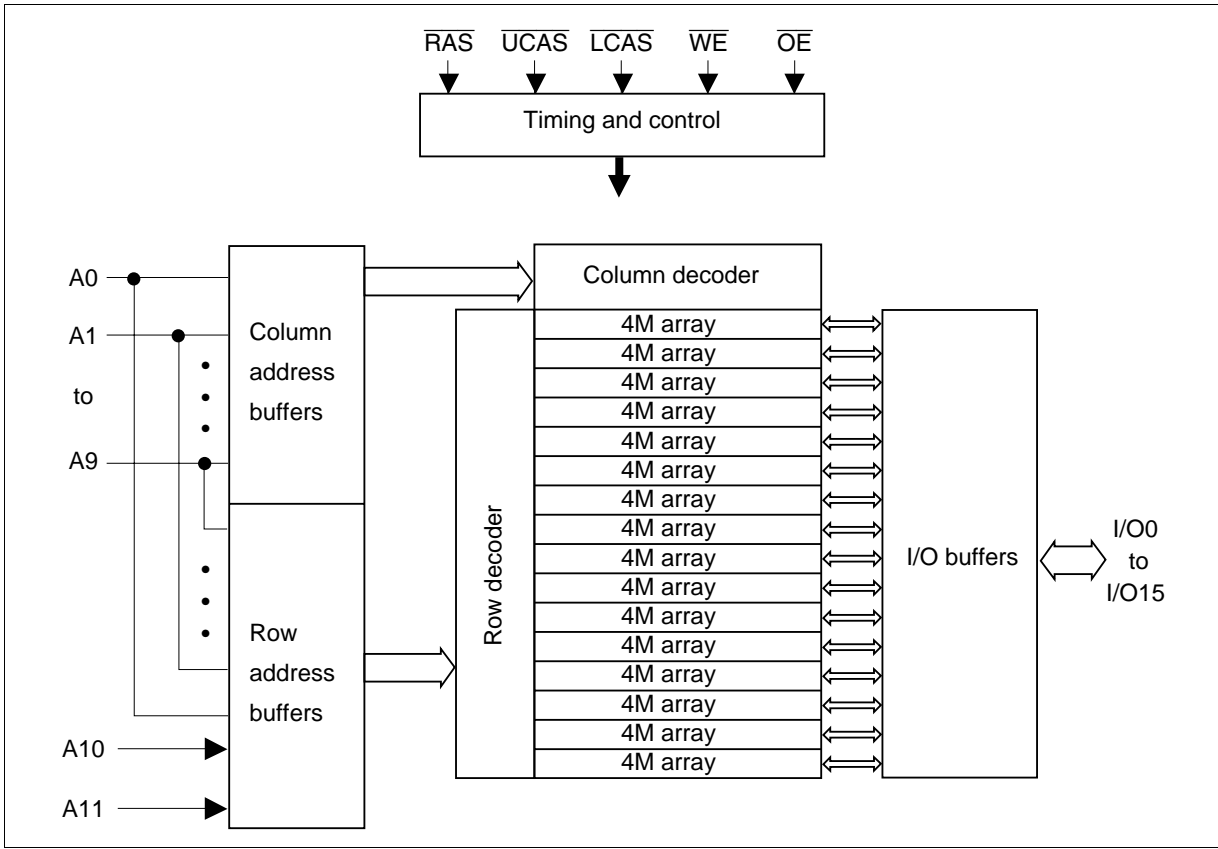

**Operation Table**

$\overline{RAS}$	$\overline{LCAS}$	$\overline{UCAS}$	$\overline{WE}$	$\overline{OE}$	I/O 0 to I/O 7	I/O 8 to I/O 15	Operation
H	×	×	×	×	High-Z	High-Z	Standby
L	L	H	H	L	Dout	High-Z	Read cycle
L	H	L	H	L	High-Z	Dout	
L	L	L	H	L	Dout	Dout	
L	L	H	L* <sup>2</sup>	×	Din	×	Early write cycle
L	H	L	L* <sup>2</sup>	×	×	Din	
L	L	L	L* <sup>2</sup>	×	Din	Din	
L	L	H	L* <sup>2</sup>	H	Din	×	Delayed write cycle
L	H	L	L* <sup>2</sup>	H	×	Din	
L	L	L	L* <sup>2</sup>	H	Din	Din	
L	L	H	H to L	L to H	Dout/Din	High-Z	Read-modify-write cycle
L	H	L	H to L	L to H	High-Z	Dout/Din	
L	L	L	H to L	L to H	Dout/Din	Dout/Din	
L	H	H	×	×	High-Z	High-Z	$\overline{RAS}$ -only refresh cycle
H to L	H	L	H	×	High-Z	High-Z	$\overline{CAS}$ -before- $\overline{RAS}$ refresh cycle or
H to L	L	H	H	×	High-Z	High-Z	Self refresh cycle (L-version)
H to L	L	L	H	×	High-Z	High-Z	
L	L	L	H	H	High-Z	High-Z	Read cycle (Output disabled)

Notes: 1. H:  $V_{IH}$  (inactive) L:  $V_{IL}$  (active) ×:  $V_{IH}$  or  $V_{IL}$

2.  $t_{WCS} \geq 0$  ns: Early write cycle

$t_{WCS} < 0$  ns: Delayed write cycle

3. Mode is determined by the OR function of the  $\overline{UCAS}$  and  $\overline{LCAS}$ . (Mode is set by the earliest of  $\overline{UCAS}$  and  $\overline{LCAS}$  active edge and reset by the latest of  $\overline{UCAS}$  and  $\overline{LCAS}$  inactive edge.) However write operation and output High-Z control are done independently by each  $\overline{UCAS}$ ,  $\overline{LCAS}$ .

ex. if  $\overline{RAS} = H$  to L,  $\overline{LCAS} = L$ ,  $\overline{UCAS} = H$ , then  $\overline{CAS}$ -before- $\overline{RAS}$  refresh cycle is selected.

**Absolute Maximum Ratings**

Parameter	Symbol	Value	Unit
Terminal voltage on any pin relative to $V_{SS}$	$V_T$	$-0.5$ to $V_{CC} + 0.5$ ( $\leq 4.6$ V (max))	V
Power supply voltage relative to $V_{SS}$	$V_{CC}$	$-0.5$ to $+4.6$	V
Short circuit output current	$I_{out}$	50	mA
Power dissipation	$P_T$	1.0	W
Storage temperature	$T_{stg}$	$-55$ to $+125$	$^{\circ}\text{C}$

**DC Operating Conditions**

Parameter	Symbol	Min	Typ	Max	Unit	Notes
Supply voltage	$V_{CC}$	3.0	3.3	3.6	V	1, 2
	$V_{SS}$	0	0	0	V	2
Input high voltage	$V_{IH}$	2.0	—	$V_{CC} + 0.3$	V	1
Input low voltage	$V_{IL}$	$-0.3$	—	0.8	V	1
Ambient temperature range	$T_a$	0	—	70	$^{\circ}\text{C}$	

Notes: 1. All voltage referred to  $V_{SS}$ .

2. The supply voltage with all  $V_{CC}$  pins must be on the same level. The supply voltage with all  $V_{SS}$  pins must be on the same level.



## DC Characteristics (HM5164165F Series)

Parameter	Symbol	HM5164165F				Unit	Test conditions
		-5		-6			
		Min	Max	Min	Max		
Operating current* <sup>1</sup> , * <sup>2</sup>	$I_{CC1}$	—	120	—	110	mA	$t_{RC} = \min$
Standby current	$I_{CC2}$	—	2	—	2	mA	TTL interface $\overline{RAS}, \overline{UCAS}, \overline{LCAS} = V_{IH}$ Dout = High-Z
		—	0.5	—	0.5	mA	CMOS interface $\overline{RAS}, \overline{UCAS},$ $\overline{LCAS} \geq V_{CC} - 0.2 \text{ V}$ Dout = High-Z
Standby current (L-version)	$I_{CC2}$	—	300	—	300	$\mu\text{A}$	CMOS interface $\overline{RAS}, \overline{UCAS},$ $\overline{LCAS} \geq V_{CC} - 0.2 \text{ V}$ Dout = High-Z
$\overline{RAS}$ -only refresh current* <sup>2</sup>	$I_{CC3}$	—	120	—	110	mA	$t_{RC} = \min$
Standby current* <sup>1</sup>	$I_{CC5}$	—	5	—	5	mA	$\overline{RAS} = V_{IH}$ $\overline{UCAS}, \overline{LCAS} = V_{IL}$ Dout = enable
$\overline{CAS}$ -before- $\overline{RAS}$ refresh current	$I_{CC6}$	—	120	—	110	mA	$t_{RC} = \min$
EDO page mode current* <sup>1</sup> , * <sup>3</sup>	$I_{CC7}$	—	120	—	110	mA	$\overline{RAS} = V_{IL}$ , $\overline{CAS}$ cycle, $t_{HPC} = t_{HPC} \text{ min}$
Battery backup current* <sup>4</sup> (Standby with CBR refresh) (L-version)	$I_{CC10}$	—	1.2	—	1.2	mA	CMOS interface Dout = High-Z CBR refresh: $t_{RC} = 15.6 \mu\text{s}$ $t_{RAS} \leq 0.3 \mu\text{s}$
Self refresh mode current (L-version)	$I_{CC11}$	—	500	—	500	$\mu\text{A}$	CMOS interface $\overline{RAS}, \overline{UCAS}, \overline{LCAS} \leq 0.2 \text{ V}$ Dout = High-Z
Input leakage current	$I_{LI}$	-5	5	-5	5	$\mu\text{A}$	$0 \text{ V} \leq V_{in} \leq V_{CC} + 0.3 \text{ V}$
Output leakage current	$I_{LO}$	-5	5	-5	5	$\mu\text{A}$	$0 \text{ V} \leq V_{out} \leq V_{CC}$ Dout = disable
Output high voltage	$V_{OH}$	2.4	$V_{CC}$	2.4	$V_{CC}$	V	High Iout = -2 mA
Output low voltage	$V_{OL}$	0	0.4	0	0.4	V	Low Iout = 2 mA

Notes: 1.  $I_{CC}$  depends on output load condition when the device is selected.  $I_{CC}$  max is specified at the output open condition.

2. Address can be changed once or less while  $\overline{RAS} = V_{IL}$ .

3. Measured with one sequential address change per EDO cycle,  $t_{HPC}$ .

4.  $V_{IH} \geq V_{CC} - 0.2 \text{ V}$ ,  $0 \text{ V} \leq V_{IL} \leq 0.2 \text{ V}$ .

# HM5164165F Series, HM5165165F Series

## DC Characteristics (HM5165165F Series)

Parameter	Symbol	HM5165165F				Unit	Test conditions
		-5		-6			
		Min	Max	Min	Max		
Operating current* <sup>1</sup> , * <sup>2</sup>	$I_{CC1}$	—	140	—	120	mA	$t_{RC} = \min$
Standby current	$I_{CC2}$	—	2	—	2	mA	TTL interface $\overline{RAS}, \overline{UCAS}, \overline{LCAS} = V_{IH}$ Dout = High-Z
		—	0.5	—	0.5	mA	CMOS interface $\overline{RAS}, \overline{UCAS},$ $\overline{LCAS} \geq V_{CC} - 0.2 V$ Dout = High-Z
Standby current (L-version)	$I_{CC2}$	—	300	—	300	$\mu A$	CMOS interface $\overline{RAS}, \overline{UCAS},$ $\overline{LCAS} \geq V_{CC} - 0.2 V$ Dout = High-Z
$\overline{RAS}$ -only refresh current* <sup>2</sup>	$I_{CC3}$	—	140	—	120	mA	$t_{RC} = \min$
Standby current* <sup>1</sup>	$I_{CC5}$	—	5	—	5	mA	$\overline{RAS} = V_{IH}$ $\overline{UCAS}, \overline{LCAS} = V_{IL}$ Dout = enable
$\overline{CAS}$ -before- $\overline{RAS}$ refresh current	$I_{CC6}$	—	140	—	120	mA	$t_{RC} = \min$
EDO page mode current* <sup>1</sup> , * <sup>3</sup>	$I_{CC7}$	—	120	—	110	mA	$\overline{RAS} = V_{IL}$ , $\overline{CAS}$ cycle, $t_{HPC} = t_{HPC} \min$
Battery backup current* <sup>4</sup> (Standby with CBR refresh) (L-version)	$I_{CC10}$	—	1.2	—	1.2	mA	CMOS interface Dout = High-Z CBR refresh: $t_{RC} = 15.6 \mu s$ $t_{RAS} \leq 0.3 \mu s$
Self refresh mode current (L-version)	$I_{CC11}$	—	500	—	500	$\mu A$	CMOS interface $\overline{RAS}, \overline{UCAS}, \overline{LCAS} \leq 0.2 V$ Dout = High-Z
Input leakage current	$I_{LI}$	-5	5	-5	5	$\mu A$	$0 V \leq V_{in} \leq V_{CC} + 0.3 V$
Output leakage current	$I_{LO}$	-5	5	-5	5	$\mu A$	$0 V \leq V_{out} \leq V_{CC}$ Dout = disable
Output high voltage	$V_{OH}$	2.4	$V_{CC}$	2.4	$V_{CC}$	V	High Iout = -2 mA
Output low voltage	$V_{OL}$	0	0.4	0	0.4	V	Low Iout = 2 mA

Notes: 1.  $I_{CC}$  depends on output load condition when the device is selected.  $I_{CC}$  max is specified at the output open condition.

2. Address can be changed once or less while  $\overline{RAS} = V_{IL}$ .

3. Measured with one sequential address change per EDO cycle,  $t_{HPC}$ .

4.  $V_{IH} \geq V_{CC} - 0.2 V$ ,  $0 V \leq V_{IL} \leq 0.2 V$ .

**Capacitance** ( $T_a = 25^\circ\text{C}$ ,  $V_{CC} = 3.3\text{ V} \pm 0.3\text{ V}$ )

Parameter	Symbol	Min	Typ	Max	Unit	Notes
Input capacitance (Address)	$C_{I1}$	—	—	5	pF	1
Input capacitance (Clocks)	$C_{I2}$	—	—	7	pF	1
Output capacitance (Data-in, Data-out)	$C_{I/O}$	—	—	7	pF	1, 2

Notes : 1. Capacitance measured with Boonton Meter or effective capacitance measuring method.

2.  $\overline{\text{RAS}}$ ,  $\overline{\text{UCAS}}$  and  $\overline{\text{LCAS}} = V_{IH}$  to disable Dout.

# HM5164165F Series, HM5165165F Series

**AC Characteristics** ( $T_a = 0$  to  $+70^\circ\text{C}$ ,  $V_{CC} = 3.3\text{ V} \pm 0.3\text{ V}$ ,  $V_{SS} = 0\text{ V}$ )\*<sup>1, \*2, \*19, \*26</sup>

## Test Conditions

- Input rise and fall time: 2 ns
- Input pulse levels:  $V_{IL} = 0\text{ V}$ ,  $V_{IH} = 3.0\text{ V}$
- Input timing reference levels: 0.8 V, 2.0 V
- Output timing reference levels: 0.8 V, 2.0 V
- Output load: 1 TTL gate +  $C_L$  (100 pF) (Including scope and jig)

## Read, Write, Read-Modify-Write and Refresh Cycles (Common parameters)

Parameter	Symbol	HM5164165F/HM5165165F				Unit	Notes
		-5		-6			
		Min	Max	Min	Max		
Random read or write cycle time	$t_{RC}$	84	—	104	—	ns	
$\overline{\text{RAS}}$ precharge time	$t_{RP}$	30	—	40	—	ns	
$\overline{\text{CAS}}$ precharge time	$t_{CP}$	8	—	10	—	ns	30
$\overline{\text{RAS}}$ pulse width	$t_{RAS}$	50	10000	60	10000	ns	
$\overline{\text{CAS}}$ pulse width	$t_{CAS}$	8	10000	10	10000	ns	
Row address setup time	$t_{ASR}$	0	—	0	—	ns	
Row address hold time	$t_{RAH}$	8	—	10	—	ns	
Column address setup time	$t_{ASC}$	0	—	0	—	ns	27
Column address hold time	$t_{CAH}$	8	—	10	—	ns	27
$\overline{\text{RAS}}$ to $\overline{\text{CAS}}$ delay time	$t_{RCD}$	12	37	14	45	ns	3
$\overline{\text{RAS}}$ to column address delay time	$t_{RAD}$	10	25	12	30	ns	4
$\overline{\text{RAS}}$ hold time	$t_{RSH}$	13	—	15	—	ns	
$\overline{\text{CAS}}$ hold time	$t_{CSH}$	35	—	40	—	ns	
$\overline{\text{CAS}}$ to $\overline{\text{RAS}}$ precharge time	$t_{CRP}$	5	—	5	—	ns	28
$\overline{\text{OE}}$ to Din delay time	$t_{OED}$	13	—	15	—	ns	5
$\overline{\text{OE}}$ delay time from Din	$t_{DZO}$	0	—	0	—	ns	6
$\overline{\text{CAS}}$ delay time from Din	$t_{DZC}$	0	—	0	—	ns	6
Transition time (rise and fall)	$t_T$	2	50	2	50	ns	7

## Read Cycle

Parameter	Symbol	HM5164165F/HM5165165F				Unit	Notes
		-5		-6			
		Min	Max	Min	Max		
Access time from $\overline{\text{RAS}}$	$t_{\text{RAC}}$	—	50	—	60	ns	8, 9
Access time from $\overline{\text{CAS}}$	$t_{\text{CAC}}$	—	13	—	15	ns	9, 10, 17
Access time from address	$t_{\text{AA}}$	—	25	—	30	ns	9, 11, 17
Access time from $\overline{\text{OE}}$	$t_{\text{OEA}}$	—	13	—	15	ns	9
Read command setup time	$t_{\text{RCS}}$	0	—	0	—	ns	27
Read command hold time to $\overline{\text{CAS}}$	$t_{\text{RCH}}$	0	—	0	—	ns	12, 28
Read command hold time from $\overline{\text{RAS}}$	$t_{\text{RCHR}}$	50	—	60	—	ns	
Read command hold time to $\overline{\text{RAS}}$	$t_{\text{RRH}}$	0	—	0	—	ns	12
Column address to $\overline{\text{RAS}}$ lead time	$t_{\text{RAL}}$	25	—	30	—	ns	
Column address to $\overline{\text{CAS}}$ lead time	$t_{\text{CAL}}$	15	—	18	—	ns	
$\overline{\text{CAS}}$ to output in low-Z	$t_{\text{CLZ}}$	0	—	0	—	ns	
Output data hold time	$t_{\text{OH}}$	3	—	3	—	ns	21
Output data hold time from $\overline{\text{OE}}$	$t_{\text{OHO}}$	3	—	3	—	ns	
Output buffer turn-off time	$t_{\text{OFF}}$	—	13	—	15	ns	13, 21
Output buffer turn-off to $\overline{\text{OE}}$	$t_{\text{OEZ}}$	—	13	—	15	ns	13
$\overline{\text{CAS}}$ to Din delay time	$t_{\text{CDD}}$	13	—	15	—	ns	5
Output data hold time from $\overline{\text{RAS}}$	$t_{\text{OHR}}$	3	—	3	—	ns	21
Output buffer turn-off to $\overline{\text{RAS}}$	$t_{\text{OFR}}$	—	13	—	15	ns	13, 21
Output buffer turn-off to $\overline{\text{WE}}$	$t_{\text{WEZ}}$	—	13	—	15	ns	13
$\overline{\text{WE}}$ to Din delay time	$t_{\text{WED}}$	13	—	15	—	ns	
$\overline{\text{RAS}}$ to Din delay time	$t_{\text{RDD}}$	13	—	15	—	ns	

# HM5164165F Series, HM5165165F Series

## Write Cycle

Parameter	Symbol	HM5164165F/HM5165165F				Unit	Notes
		-5		-6			
		Min	Max	Min	Max		
Write command setup time	$t_{WCS}$	0	—	0	—	ns	14, 27
Write command hold time	$t_{WCH}$	8	—	10	—	ns	27
Write command pulse width	$t_{WP}$	8	—	10	—	ns	
Write command to $\overline{RAS}$ lead time	$t_{RWL}$	13	—	15	—	ns	
Write command to $\overline{CAS}$ lead time	$t_{CWL}$	8	—	10	—	ns	29
Data-in setup time	$t_{DS}$	0	—	0	—	ns	15, 29
Data-in hold time	$t_{DH}$	8	—	10	—	ns	15, 29

## Read-Modify-Write Cycle

Parameter	Symbol	HM5164165F/HM5165165F				Unit	Notes
		-5		-6			
		Min	Max	Min	Max		
Read-modify-write cycle time	$t_{RWC}$	116	—	140	—	ns	
$\overline{RAS}$ to $\overline{WE}$ delay time	$t_{RWD}$	67	—	79	—	ns	14
$\overline{CAS}$ to $\overline{WE}$ delay time	$t_{CWD}$	30	—	34	—	ns	14
Column address to $\overline{WE}$ delay time	$t_{AWD}$	42	—	49	—	ns	14
$\overline{OE}$ hold time from $\overline{WE}$	$t_{OEH}$	13	—	15	—	ns	

## Refresh Cycle

Parameter	Symbol	HM5164165F/HM5165165F				Unit	Notes
		-5		-6			
		Min	Max	Min	Max		
$\overline{CAS}$ setup time (CBR refresh cycle)	$t_{CSR}$	5	—	5	—	ns	27
$\overline{CAS}$ hold time (CBR refresh cycle)	$t_{CHR}$	8	—	10	—	ns	28
$\overline{WE}$ setup time (CBR refresh cycle)	$t_{WRP}$	0	—	0	—	ns	
$\overline{WE}$ hold time (CBR refresh cycle)	$t_{WRH}$	8	—	10	—	ns	
$\overline{RAS}$ precharge to $\overline{CAS}$ hold time	$t_{RPC}$	5	—	5	—	ns	27

## EDO Page Mode Cycle

Parameter	Symbol	HM5164165F/HM5165165F				Unit	Notes
		-5		-6			
		Min	Max	Min	Max		
EDO page mode cycle time	$t_{HPC}$	20	—	25	—	ns	20
EDO page mode $\overline{RAS}$ pulse width	$t_{RASP}$	—	100000	—	100000	ns	16
Access time from $\overline{CAS}$ precharge	$t_{CPA}$	—	28	—	35	ns	9, 17, 28
$\overline{RAS}$ hold time from $\overline{CAS}$ precharge	$t_{CPRH}$	28	—	35	—	ns	
Output data hold time from $\overline{CAS}$ low	$t_{DOH}$	3	—	3	—	ns	9, 22
$\overline{CAS}$ hold time referred $\overline{OE}$	$t_{COL}$	8	—	10	—	ns	
$\overline{CAS}$ to $\overline{OE}$ setup time	$t_{COP}$	5	—	5	—	ns	
Read command hold time from $\overline{CAS}$ precharge	$t_{RCHC}$	28	—	35	—	ns	
Write pulse width during $\overline{CAS}$ precharge	$t_{WPE}$	8	—	10	—	ns	
$\overline{OE}$ precharge time	$t_{OEP}$	8	—	10	—	ns	

## EDO Page Mode Read-Modify-Write Cycle

Parameter	Symbol	HM5164165F/HM5165165F				Unit	Notes
		-5		-6			
		Min	Max	Min	Max		
EDO page mode read-modify-write cycle time	$t_{HPRWC}$	57	—	68	—	ns	
$\overline{WE}$ delay time from $\overline{CAS}$ precharge	$t_{CPW}$	45	—	54	—	ns	14, 28

## Refresh (HM5164165F Series)

Parameter	Symbol	Max	Unit	Note
Refresh period	$t_{REF}$	64	ms	8192 cycles

# HM5164165F Series, HM5165165F Series

## Refresh (HM5165165F Series)

Parameter	Symbol	Max	Unit	Note
Refresh period	$t_{REF}$	64	ms	4096 cycles

## Self Refresh Mode (L-version)

Parameter	Symbol	HM5164165FL/HM5165165FL				Unit	Notes
		-5		-6			
		Min	Max	Min	Max		
$\overline{RAS}$ pulse width (self refresh)	$t_{RASS}$	100	—	100	—	$\mu$ s	25
$\overline{RAS}$ precharge time (self refresh)	$t_{RPS}$	90	—	110	—	ns	25
$\overline{CAS}$ hold time (self refresh)	$t_{CHS}$	-50	—	-50	—	ns	29

Notes: 1. AC measurements assume  $t_T = 2$  ns.

- An initial pause of 200  $\mu$ s is required after power up followed by a minimum of eight initialization cycles (any combination of cycles containing  $\overline{RAS}$ -only refresh or  $\overline{CAS}$ -before- $\overline{RAS}$  refresh).
- Operation with the  $t_{RCD}$  (max) limit insures that  $t_{RAC}$  (max) can be met,  $t_{RCD}$  (max) is specified as a reference point only; if  $t_{RCD}$  is greater than the specified  $t_{RCD}$  (max) limit, then the access time is controlled exclusively by  $t_{CAC}$ .
- Operation with the  $t_{RAD}$  (max) limit insures that  $t_{RAC}$  (max) can be met,  $t_{RAD}$  (max) is specified as a reference point only; if  $t_{RAD}$  is greater than the specified  $t_{RAD}$  (max) limit, then access time is controlled exclusively by  $t_{AA}$ .
- Either  $t_{OED}$  or  $t_{CDD}$  must be satisfied.
- Either  $t_{DZO}$  or  $t_{DZC}$  must be satisfied.
- $V_{IH}$  (min) and  $V_{IL}$  (max) are reference levels for measuring timing of input signals. Also, transition times are measured between  $V_{IH}$  (min) and  $V_{IL}$  (max).
- Assumes that  $t_{RCD} \leq t_{RCD}$  (max) and  $t_{RAD} \leq t_{RAD}$  (max). If  $t_{RCD}$  or  $t_{RAD}$  is greater than the maximum recommended value shown in this table,  $t_{RAC}$  exceeds the value shown.
- Measured with a load circuit equivalent to 1 TTL loads and 100 pF.
- Assumes that  $t_{RCD} \geq t_{RCD}$  (max) and  $t_{RCD} + t_{CAC}$  (max)  $\geq t_{RAD} + t_{AA}$  (max).
- Assumes that  $t_{RAD} \geq t_{RAD}$  (max) and  $t_{RCD} + t_{CAC}$  (max)  $\leq t_{RAD} + t_{AA}$  (max).
- Either  $t_{RCH}$  or  $t_{RRH}$  must be satisfied for a read cycles.
- $t_{OFF}$  (max),  $t_{OEZ}$  (max),  $t_{WEZ}$  (max) and  $t_{OFR}$  (max) define the time at which the outputs achieve the open circuit condition and are not referred to output voltage levels.
- $t_{WCS}$ ,  $t_{RWD}$ ,  $t_{CWD}$ ,  $t_{AWD}$  and  $t_{CPW}$  are not restrictive operating parameters. They are included in the data sheet as electrical characteristics only; if  $t_{WCS} \geq t_{WCS}$  (min), the cycle is an early write cycle and the data out pin will remain open circuit (high impedance) throughout the entire cycle; if  $t_{RWD} \geq t_{RWD}$  (min),  $t_{CWD} \geq t_{CWD}$  (min), and  $t_{AWD} \geq t_{AWD}$  (min), or  $t_{CWD} \geq t_{CWD}$  (min),  $t_{AWD} \geq t_{AWD}$  (min) and  $t_{CPW} \geq t_{CPW}$  (min), the cycle is a read-modify-write and the data output will contain data read from the selected cell; if neither of the above sets of conditions is satisfied, the condition of the data out (at access time) is indeterminate.
- $t_{DS}$  and  $t_{DH}$  are referred to  $\overline{UCAS}$  and  $\overline{LCAS}$  leading edge in early write cycles and to  $\overline{WE}$  leading edge in delayed write or read-modify-write cycles.



16.  $t_{RASP}$  defines  $\overline{RAS}$  pulse width in EDO page mode cycles.
17. Access time is determined by the longest among  $t_{AA}$ ,  $t_{CAC}$  and  $t_{CPA}$ .
18. In delayed write or read-modify-write cycles,  $\overline{OE}$  must disable output buffer prior to applying data to the device.
19. When output buffers are enabled once, sustain the low impedance state until valid data is obtained. When output buffer is turned on and off within a very short time, generally it causes large  $V_{CC}/V_{SS}$  line noise, which causes to degrade  $V_{IH\ min}/V_{IL\ max}$  level.
20.  $t_{HPC}$  (min) can be achieved during a series of EDO page mode write cycles or EDO page mode read cycles. If both write and read operation are mixed in a EDO page mode  $\overline{RAS}$  cycle (EDO page mode mix cycle (1), (2)), minimum value of  $\overline{CAS}$  cycle ( $t_{CAS} + t_{CP} + 2 t_T$ ) becomes greater than the specified  $t_{HPC}$  (min) value. The value of  $\overline{CAS}$  cycle time of mixed EDO page mode is shown in EDO page mode mix cycle (1) and (2).
21. Data output turns off and becomes high impedance after rising edge of  $\overline{RAS}$  and  $\overline{CAS}$ . Hold time and turn off time are specified by the timing specifications of later rising edge of  $\overline{RAS}$  and  $\overline{CAS}$  between  $t_{OHR}$  and  $t_{OH}$ , and between  $t_{OFR}$  and  $t_{OFF}$ .
22.  $t_{DOH}$  defines the time at which the output level go cross.  $V_{OL} = 0.8 V$ ,  $V_{OH} = 2.0 V$  of output timing reference level.
23. Before and after self refresh mode, execute CBR refresh to all refresh addresses in or within 64 ms period on the condition a and b below.
  - a. Enter self refresh mode within 15.6  $\mu s$  after either burst refresh or distributed refresh at equal interval to all refresh addresses are completed.
  - b. Start burst refresh or distributed refresh at equal interval to all refresh addresses within 15.6  $\mu s$  after exiting from self refresh mode.
24. In case of entering from  $\overline{RAS}$ -only-refresh, it is necessary to execute CBR refresh before and after self refresh mode according as note 23.
25. At  $t_{RASS} > 100 \mu s$ , self refresh mode is activated, and not activated at  $t_{RASS} < 10 \mu s$ . It is undefined within the range of  $10 \mu s \leq t_{RASS} \leq 100 \mu s$ . For  $t_{RASS} \geq 10 \mu s$ , it is necessary to satisfy  $t_{RPS}$ .
26. When both  $\overline{UCAS}$  and  $\overline{LCAS}$  go low at the same time, all 16-bit data are written into the device.  $\overline{UCAS}$  and  $\overline{LCAS}$  cannot be staggered within the same write/read cycles.
27.  $t_{ASC}$ ,  $t_{CAH}$ ,  $t_{RCS}$ ,  $t_{WCS}$ ,  $t_{WCH}$ ,  $t_{CSR}$  and  $t_{RPC}$  are determined by the earlier falling edge of  $\overline{UCAS}$  or  $\overline{LCAS}$ .
28.  $t_{CRP}$ ,  $t_{CHR}$ ,  $t_{RCH}$ ,  $t_{CPA}$  and  $t_{CPW}$  are determined by the later rising edge of  $\overline{UCAS}$  or  $\overline{LCAS}$ .
29.  $t_{CWL}$ ,  $t_{DH}$ ,  $t_{DS}$  and  $t_{CHS}$  should be satisfied by both  $\overline{UCAS}$  and  $\overline{LCAS}$ .
30.  $t_{CP}$  is determined by the time that both  $\overline{UCAS}$  and  $\overline{LCAS}$  are high.
31. XXX: H or L (H:  $V_{IH}(\min) \leq V_{IN} \leq V_{IH}(\max)$ , L:  $V_{IL}(\min) \leq V_{IN} \leq V_{IL}(\max)$ )  
 //////////////: Invalid Dout  
 When the address, clock and input pins are not described on timing waveforms, their pins must be applied  $V_{IH}$  or  $V_{IL}$ .

## Notes concerning $\overline{2CAS}$ control

Please do not separate the  $\overline{UCAS/LCAS}$  operation timing intentionally. However skew between  $\overline{UCAS/LCAS}$  are allowed under the following conditions.

1. Each of the  $\overline{UCAS/LCAS}$  should satisfy the timing specifications individually.
2. Different operation mode for upper/lower byte is not allowed; such as following.

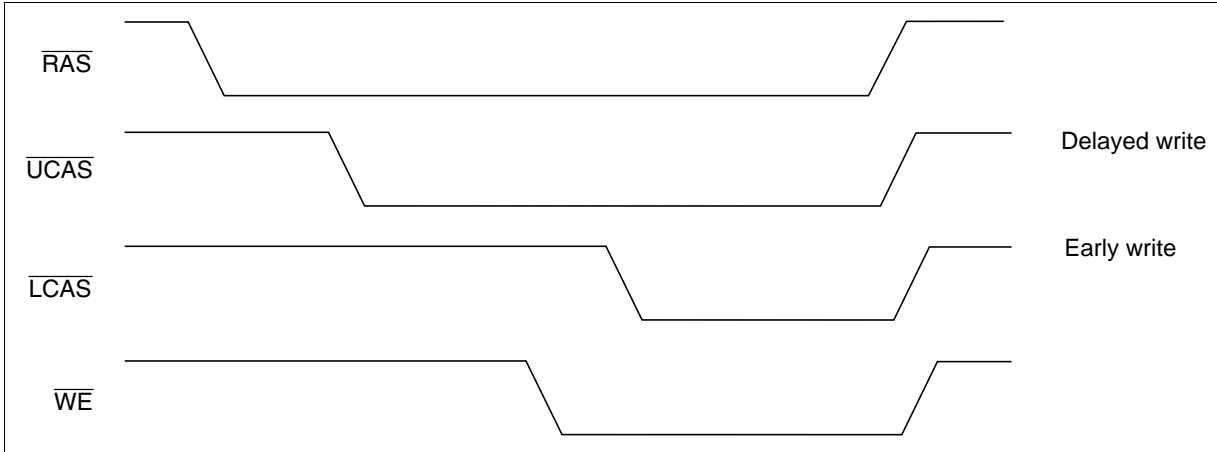

3. Closely separated upper/lower byte control is not allowed. However when the condition ( $t_{CP} \leq t_{UL}$ ) is satisfied, EDO page mode can be performed.

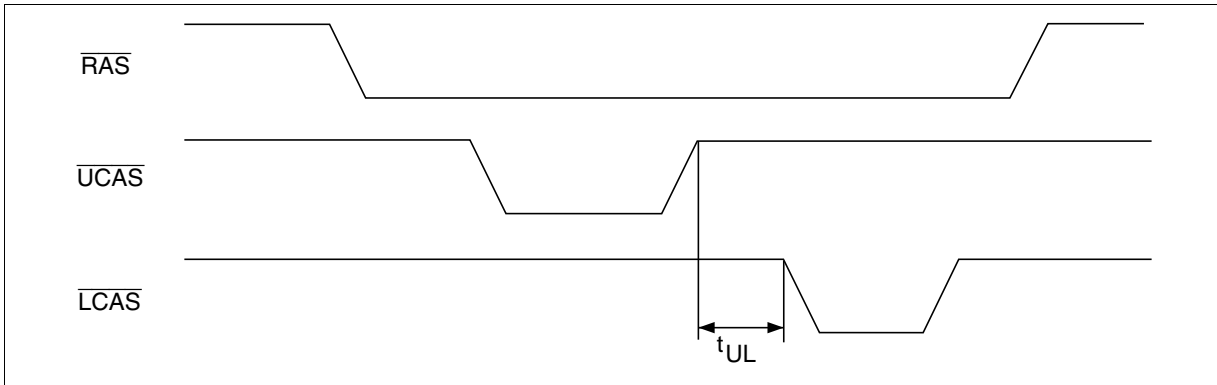

4. Byte control operation by remaining  $\overline{UCAS}$  or  $\overline{LCAS}$  high is guaranteed.

Timing Waveforms\*31

Read Cycle

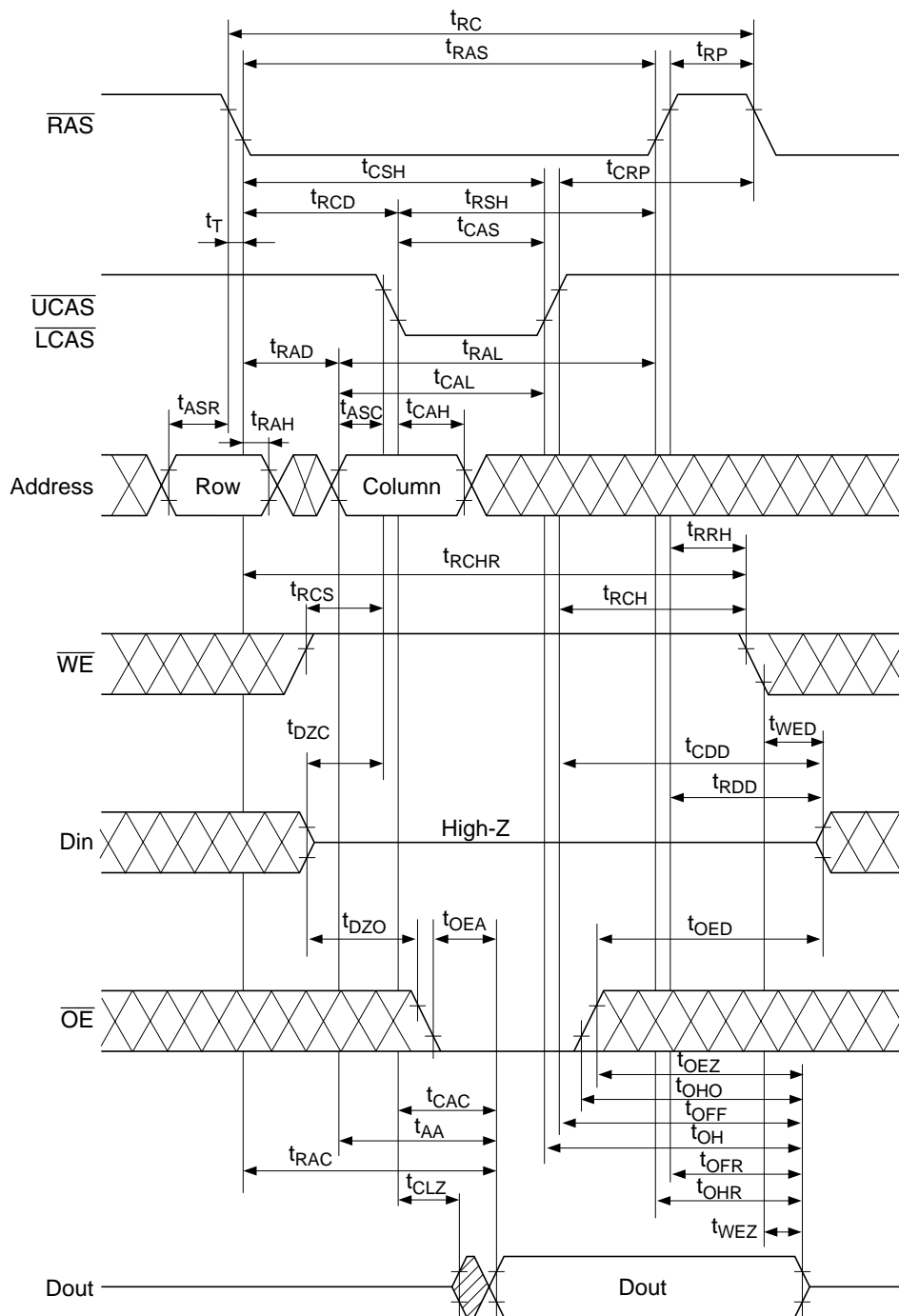

## Early Write Cycle

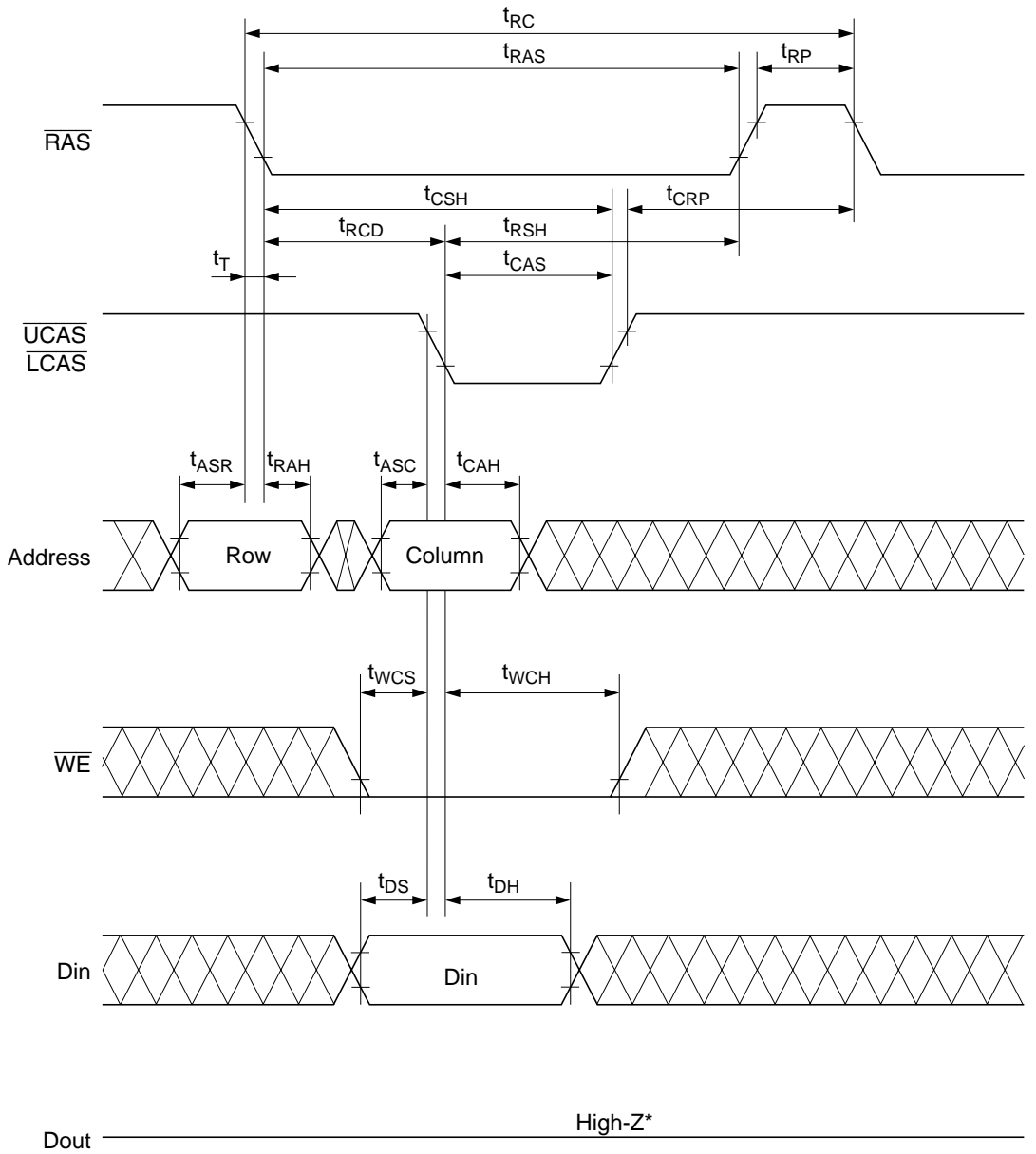

\*  $t_{WCS} \geq t_{WCS}(\text{min})$

Delayed Write Cycle\*18

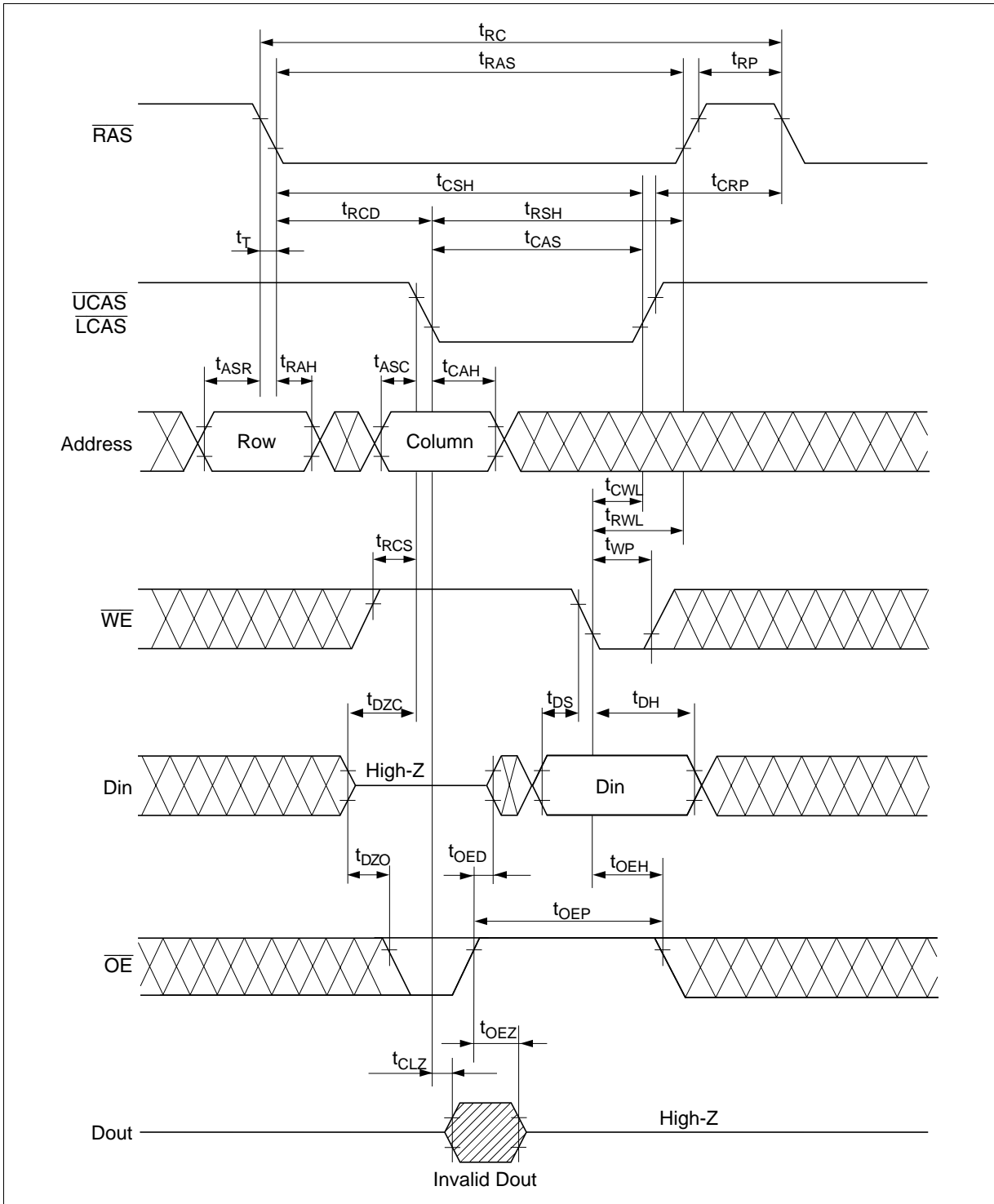



RAS-Only Refresh Cycle

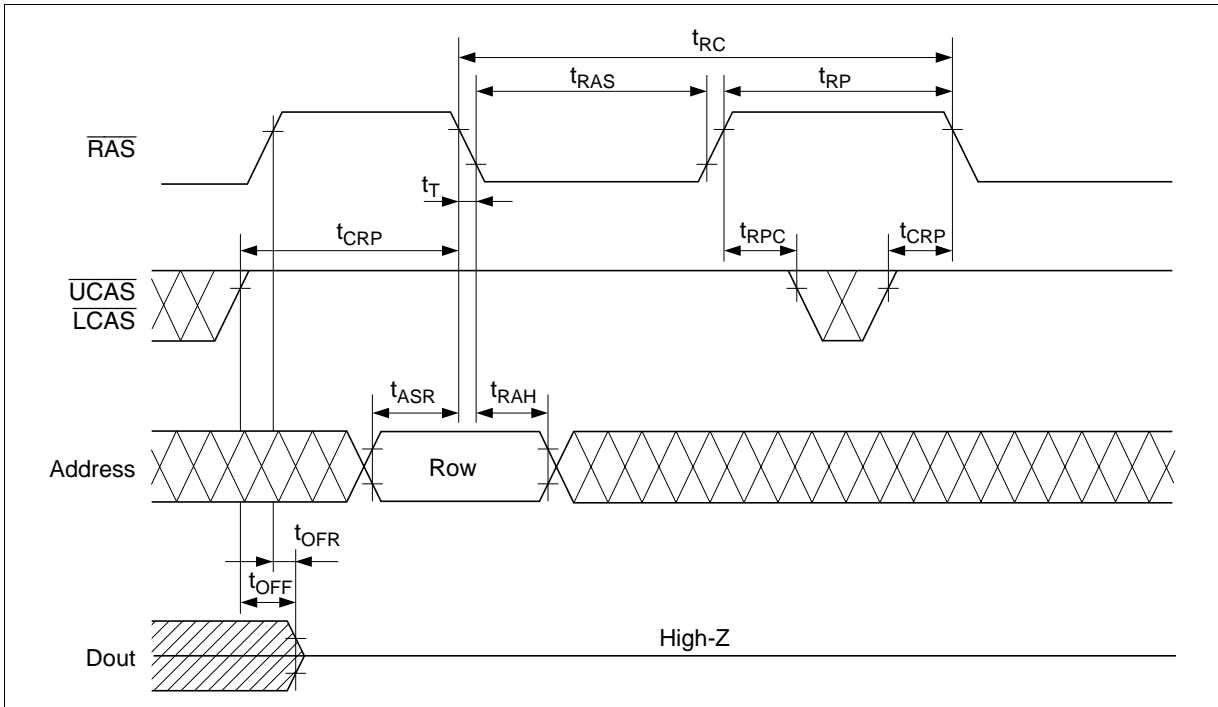

## CAS-Before-RAS Refresh Cycle

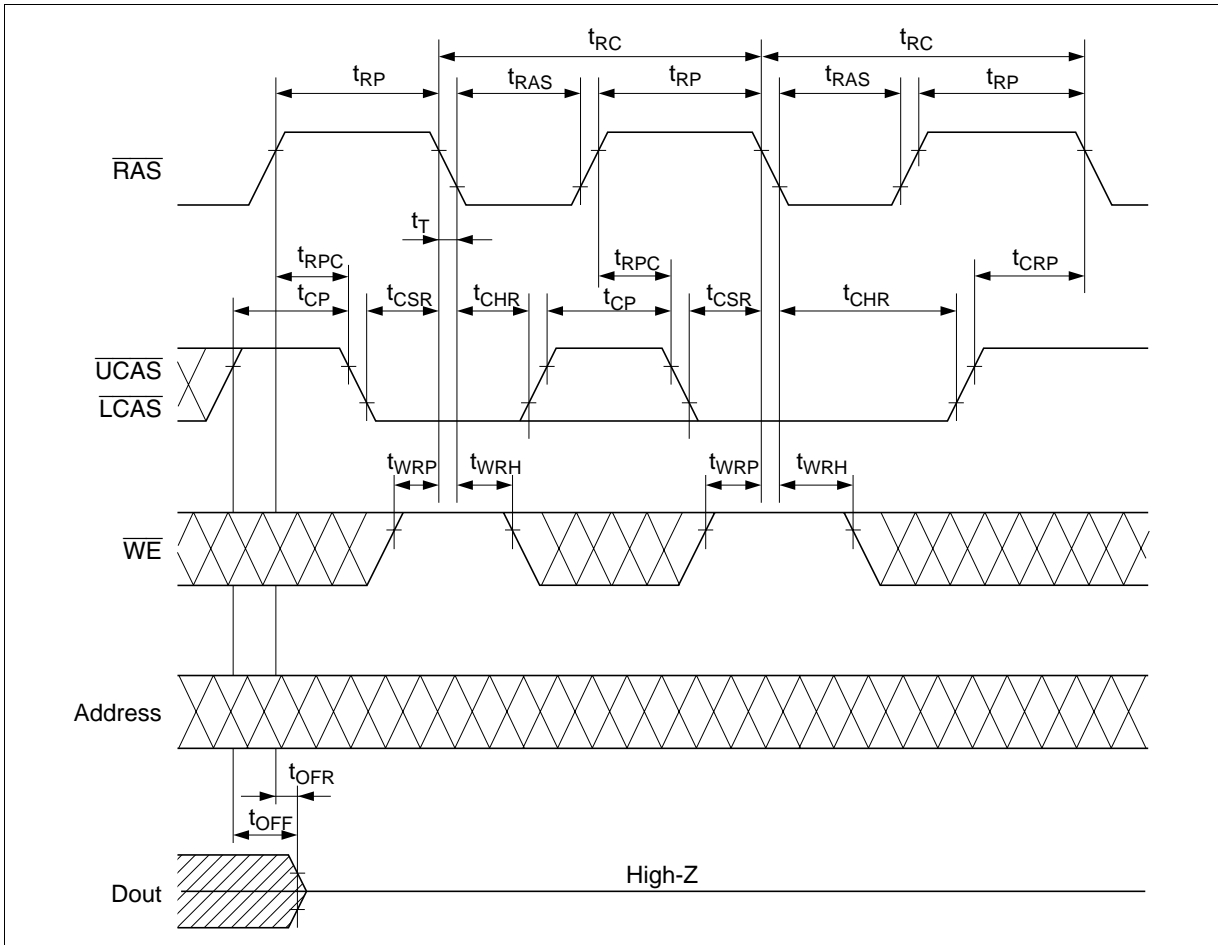



Hidden Refresh Cycle

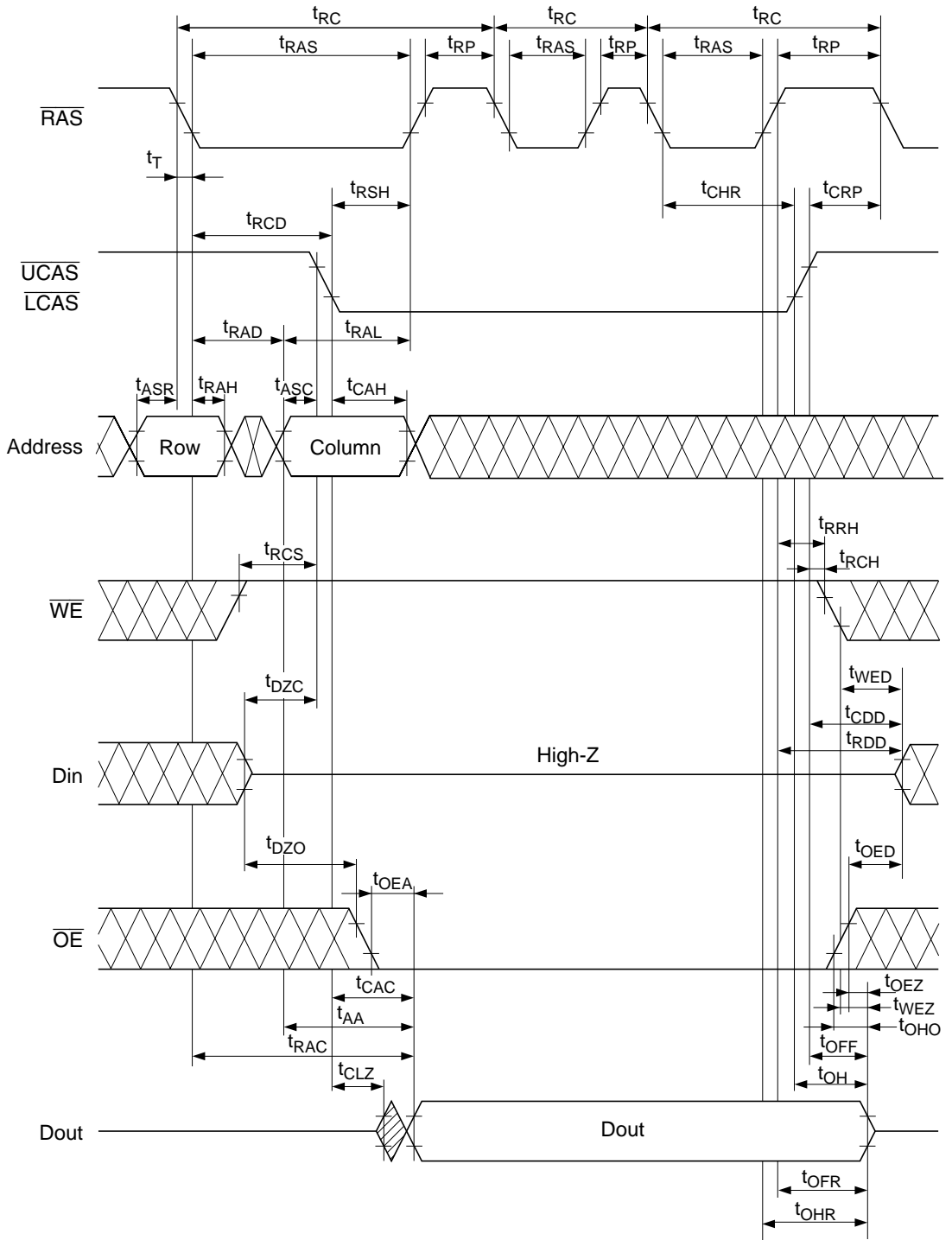





## EDO Page Mode Early Write Cycle

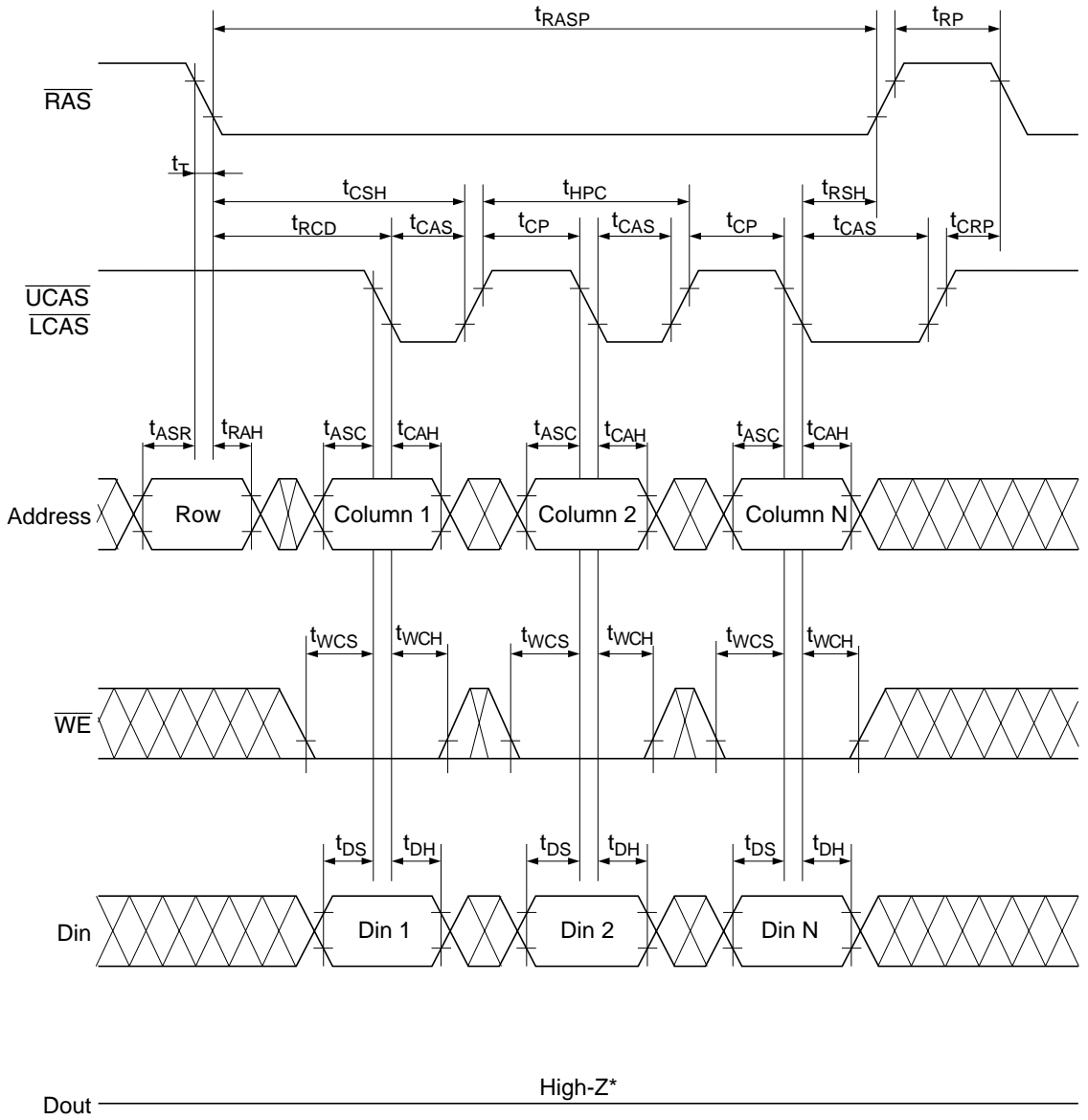

\*  $t_{WCS} \geq t_{WCS}(\text{min})$

EDO Page Mode Delayed Write Cycle\*18

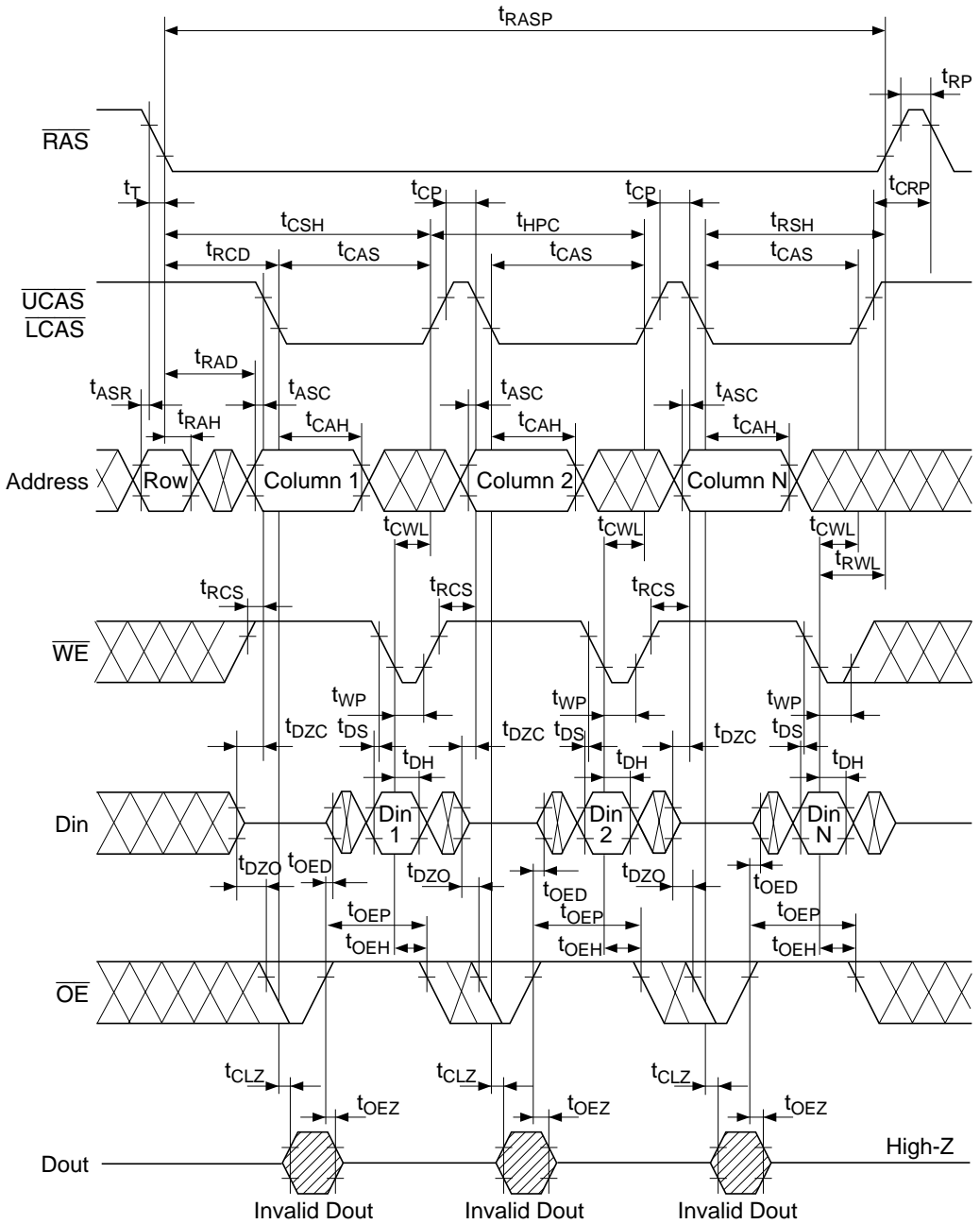

## EDO Page Mode Read-Modify-Write Cycle\*18

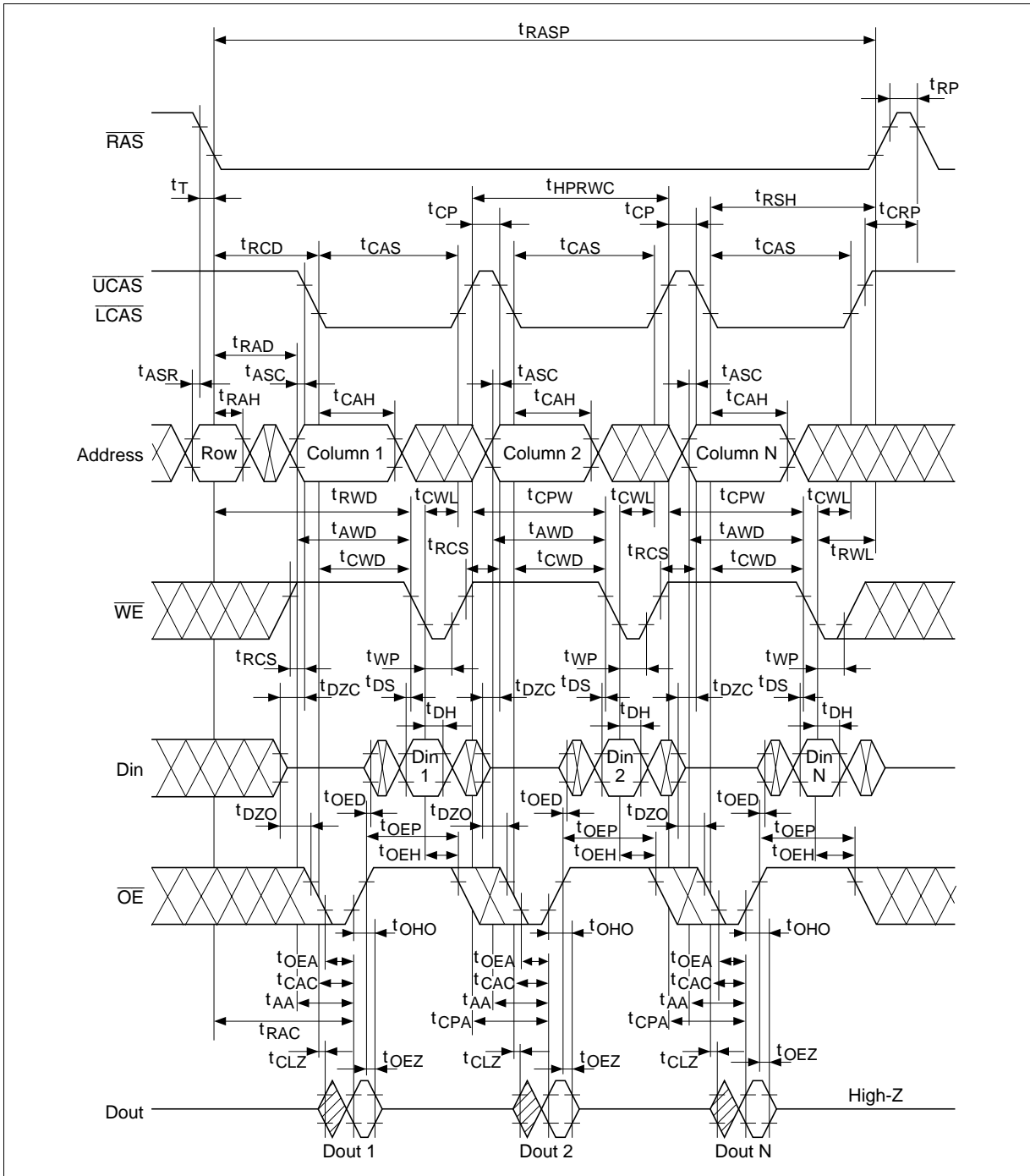



## EDO Page Mode Mix Cycle (2)\*20

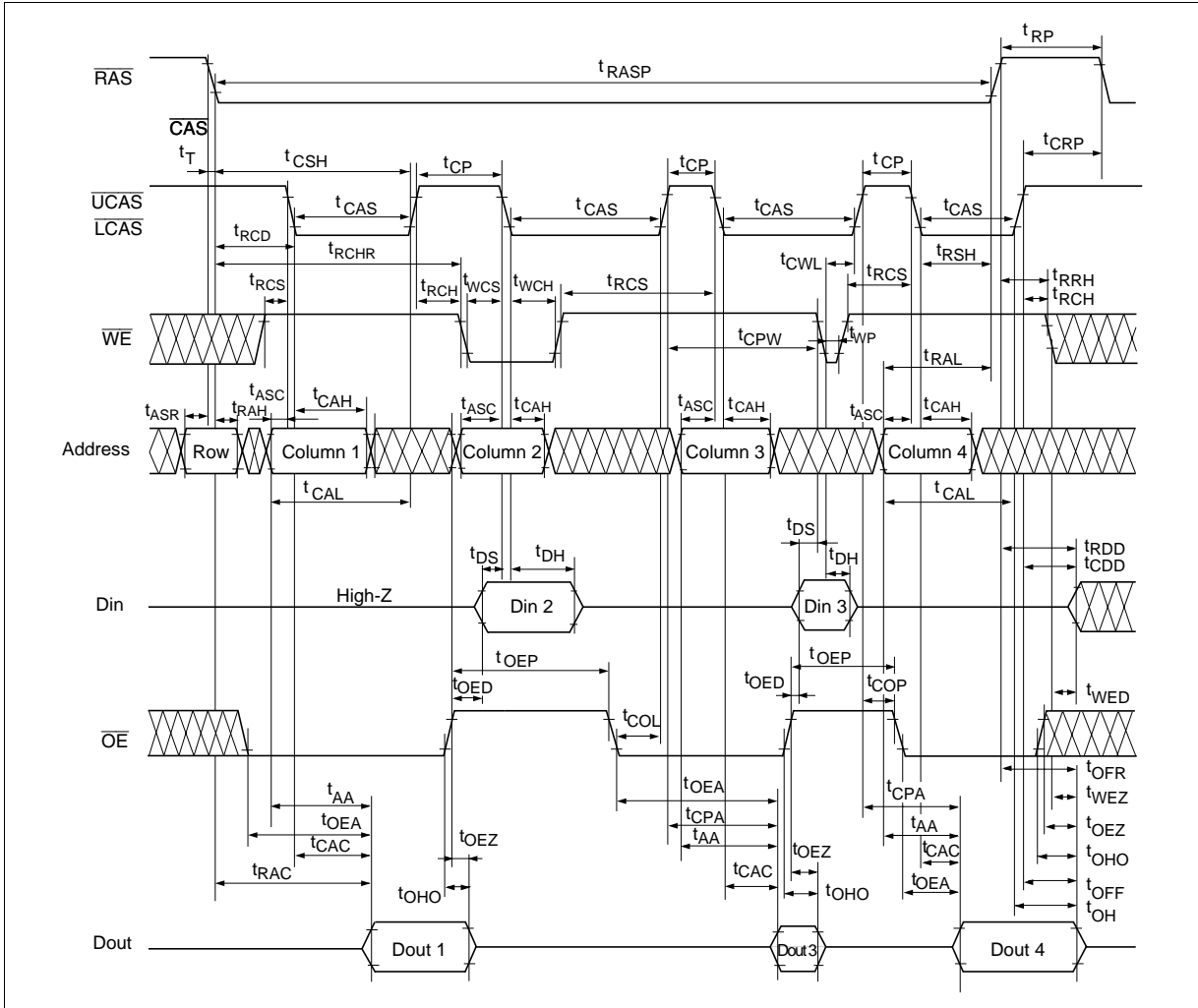



Self Refresh Cycle (L-version)\*23, 24, 25

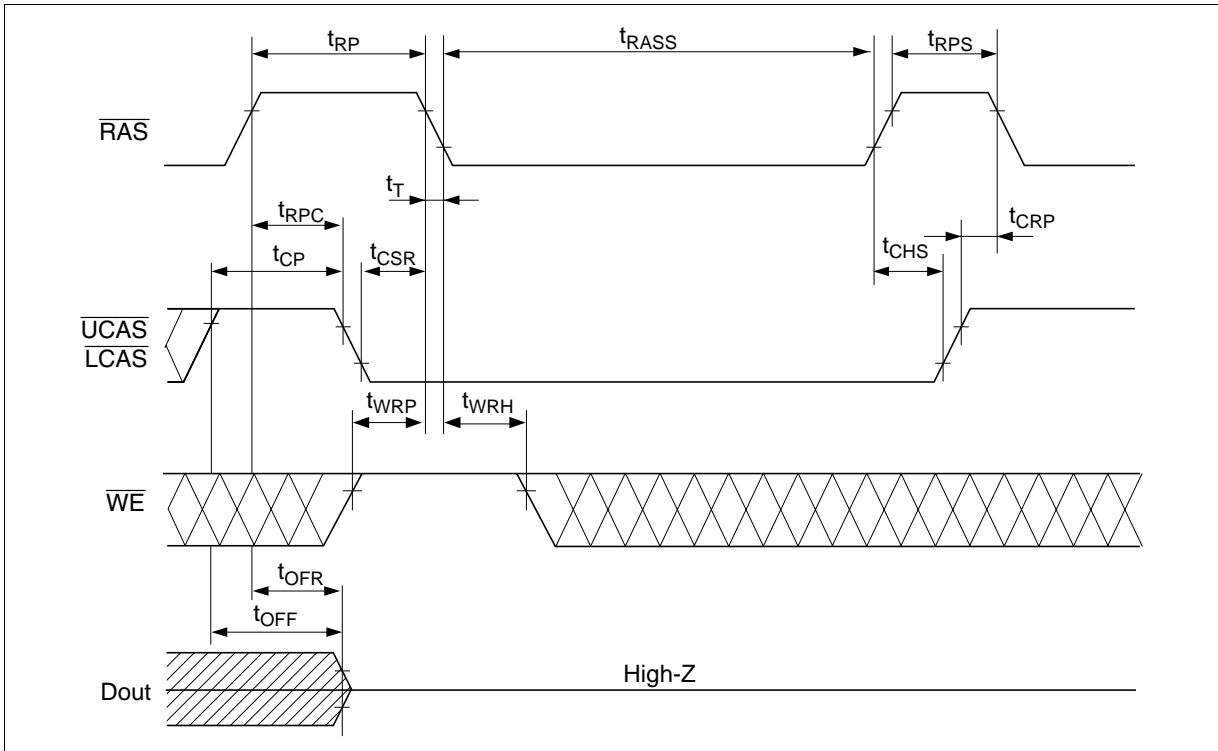

# HM5164165F Series, HM5165165F Series

## Package Dimensions

HM5164165FJ/FLJ Series

HM5165165FJ/FLJ Series (CP-50DA)

Unit: mm

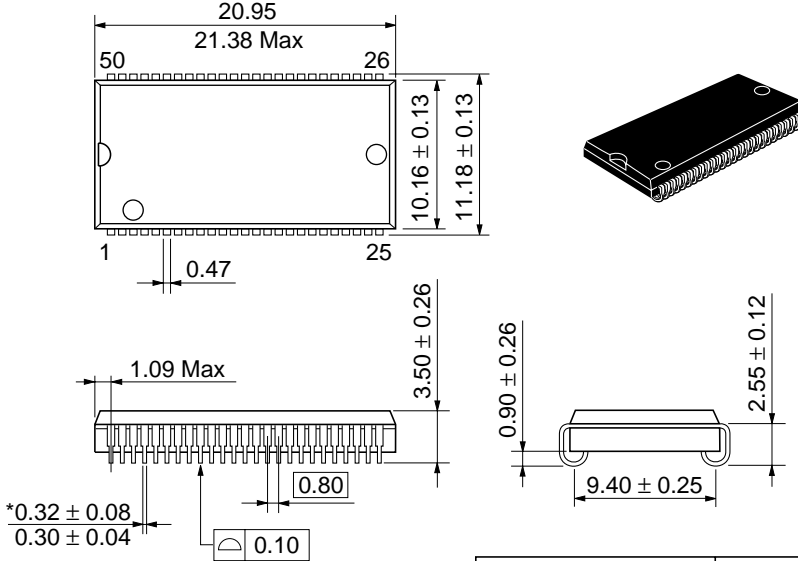

\*Dimension including the plating thickness  
Base material dimension

Hitachi Code	CP-50DA
JEDEC	Conforms
EIAJ	—
Weight (reference value)	1.2 g

## HM5164165FTT/FLTT Series

## HM5165165FTT/FLTT Series (TTP-50DB)

Unit: mm

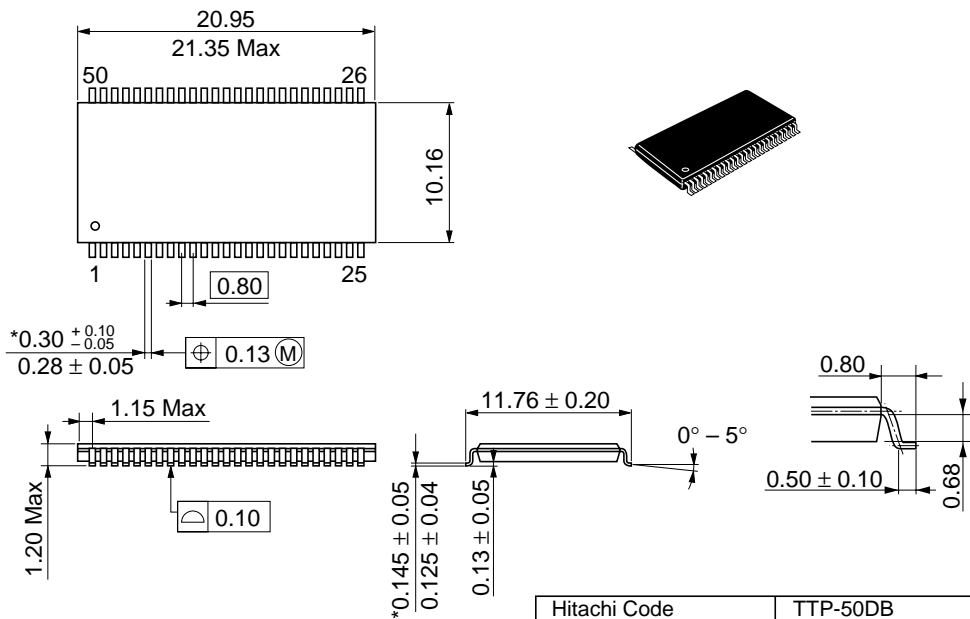

\*Dimension including the plating thickness  
Base material dimension

Hitachi Code	TTP-50DB
JEDEC	—
EIAJ	—
Weight (reference value)	0.51 g

## Cautions

1. Hitachi neither warrants nor grants licenses of any rights of Hitachi's or any third party's patent, copyright, trademark, or other intellectual property rights for information contained in this document. Hitachi bears no responsibility for problems that may arise with third party's rights, including intellectual property rights, in connection with use of the information contained in this document.
2. Products and product specifications may be subject to change without notice. Confirm that you have received the latest product standards or specifications before final design, purchase or use.
3. Hitachi makes every attempt to ensure that its products are of high quality and reliability. However, contact Hitachi's sales office before using the product in an application that demands especially high quality and reliability or where its failure or malfunction may directly threaten human life or cause risk of bodily injury, such as aerospace, aeronautics, nuclear power, combustion control, transportation, traffic, safety equipment or medical equipment for life support.
4. Design your application so that the product is used within the ranges guaranteed by Hitachi particularly for maximum rating, operating supply voltage range, heat radiation characteristics, installation conditions and other characteristics. Hitachi bears no responsibility for failure or damage when used beyond the guaranteed ranges. Even within the guaranteed ranges, consider normally foreseeable failure rates or failure modes in semiconductor devices and employ systemic measures such as fail-safes, so that the equipment incorporating Hitachi product does not cause bodily injury, fire or other consequential damage due to operation of the Hitachi product.
5. This product is not designed to be radiation resistant.
6. No one is permitted to reproduce or duplicate, in any form, the whole or part of this document without written approval from Hitachi.
7. Contact Hitachi's sales office for any questions regarding this document or Hitachi semiconductor products.

# HITACHI

## Hitachi, Ltd.

Semiconductor & Integrated Circuits.

Nippon Bldg., 2-6-2, Ohite-machi, Chiyoda-ku, Tokyo 100-0004, Japan

Tel: Tokyo (03) 3270-2111 Fax: (03) 3270-5109

URL      NorthAmerica      : <http://semiconductor.hitachi.com/>  
             Europe                : <http://www.hitachi-eu.com/hel/ecg>  
             Asia (Singapore)        : <http://www.has.hitachi.com.sg/grp3/sicd/index.htm>  
             Asia (Taiwan)            : [http://www.hitachi.com.tw/E/Product/SICD\\_Frame.htm](http://www.hitachi.com.tw/E/Product/SICD_Frame.htm)  
             Asia (HongKong)         : <http://www.hitachi.com.hk/eng/bo/grp3/index.htm>  
             Japan                     : <http://www.hitachi.co.jp/Sicd/indx.htm>

## For further information write to:

Hitachi Semiconductor  
(America) Inc.  
179 East Tasman Drive,  
San Jose, CA 95134  
Tel: <1> (408) 433-1990  
Fax: <1> (408) 433-0223

Hitachi Europe GmbH  
Electronic components Group  
Dornacher Straße 3  
D-85622 Feldkirchen, Munich  
Germany  
Tel: <49> (89) 9 9180-0  
Fax: <49> (89) 9 29 30 00

Hitachi Europe Ltd.  
Electronic Components Group.  
Whitebrook Park  
Lower Cookham Road  
Maidenhead  
Berkshire SL6 8YA, United Kingdom  
Tel: <44> (1628) 585000  
Fax: <44> (1628) 778322

Hitachi Asia Pte. Ltd.  
16 Collyer Quay #20-00  
Hitachi Tower  
Singapore 049318  
Tel: 535-2100  
Fax: 535-1533

Hitachi Asia Ltd.  
Taipei Branch Office  
3F, Hung Kuo Building, No.167,  
Tun-Hwa North Road, Taipei (105)  
Tel: <886> (2) 2718-3666  
Fax: <886> (2) 2718-8180

Hitachi Asia (Hong Kong) Ltd.  
Group III (Electronic Components)  
7/F., North Tower, World Finance Centre,  
Harbour City, Canton Road, Tsim Sha Tsui,  
Kowloon, Hong Kong  
Tel: <852> (2) 735 9218  
Fax: <852> (2) 730 0281  
Telex: 40815 HITEC HX

Copyright © Hitachi, Ltd., 1998. All rights reserved. Printed in Japan.

**Revision Record**

<b>Rev.</b>	<b>Date</b>	<b>Contents of Modification</b>	<b>Drawn by</b>	<b>Approved by</b>
0.0	May. 25, 1999	Initial issue	M. Kawamura	M. Mishima
1.0	Oct. 5, 1999	Features: Change of Power dissipation Standby (L-version) max: TBD to 1.1 mW DC Characteristics $I_{CC2}$ (L-version) max: TBD/TBD to 300/300 $\mu$ A $I_{CC10}$ (L-version) max: TBD/TBD to 1/1 mA $I_{CC11}$ (L-version) max: TBD/TBD to 500/500 $\mu$ A	M. Kawamura	Y. Kasama
2.0	Nov. 30, 1999	DC Characteristics $I_{CC10}$ (L-version) max: 1/1 mA to 1.2/1.2 mA		

---