

T-41-37

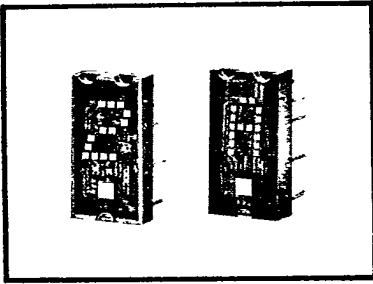

Hexadecimal Display with integral TTL MSI Circuit Chip

character height: .270"
745-0007

The display and TTL MSI chip are mounted on a lead-frame assembly which is then cast within an electrically nonconductive, transparent epoxy. Multiple displays may be mounted on 0.450 inch centers.

mechanical data

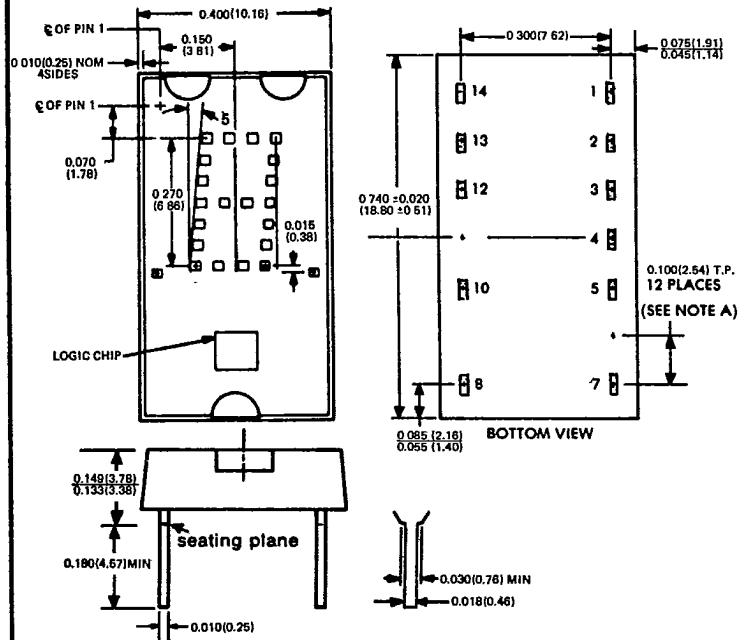

NOTES:

- A. The true position pin spacing is 0.100 between centerlines. Each pin centerline is located within ±0.010 of its true longitudinal position relative to pins 1 and 14.
- B. Lead dimensions are not controlled above the seating plane.
- C. Dimensions associated with position of LED's are between centerlines and are nominal.
- D. All dimensions are in inches unless otherwise specified.

- PIN 1 LED SUPPLY VOLTAGE
- PIN 2 LATCH DATA INPUT B
- PIN 3 LATCH DATA INPUT A
- PIN 4 LEFT DECIMAL POINT CATHODE
- PIN 5 LATCH STROBE INPUT
- PIN 6 OMITTED
- PIN 7 COMMON GROUND
- PIN 8 BLANKING INPUT
- PIN 9 OMITTED
- PIN 10 RIGHT DECIMAL POINT CATHODE
- PIN 11 OMITTED
- PIN 12 LATCH DATA INPUT D
- PIN 13 LATCH DATA INPUT C
- PIN 14 LOGIC SUPPLY VOLTAGE, VCC

() Metric dimension in mm.

Solid-State Visible Hexadecimal Display With Integral TTL Circuit To Accept, Store, And Display 4-Bit Binary Data

- 0.270-Inch-High Character
- High Brightness
- Left-and-Right-Hand Decimals
- Separate LED and Logic Power Supplies May Be Used
- Easy System Interface
- Single-Plane Wide-Angle Visibility
- Internal TTL MSI Chip with Latch, Decoder, and Driver
- Operates from 5-Volt or 6-Volt Supply
- Constant-Current Drive for Hexadecimal Characters

connector 501-0701-009

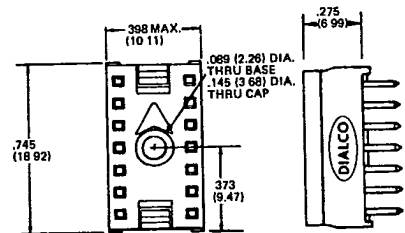

For use with 745-0007 display.

Dialight reserves the right to make changes at anytime in order to improve design and to supply the best product possible.

description 745-0007

This hexadecimal display contains a four-bit latch, de coder, driver, and 4x7 light-emitting-diode (LED) character with two externally-driven decimal points in a 14-pin package. A description of the functions of the inputs of this device follows.

	PIN NO.	DESCRIPTION
LATCH STROBE INPUT	5	When low, the data in the latches follow the data on the latch data inputs. When high, the data in the latches will not change. If the display is blanked and then restored while the enable input is high, the previous character will again be displayed.
BLANKING INPUT	8	When high, the display is blanked regardless of the levels of the other inputs. When low, a character is displayed as determined by the data in the latches. The blanking input may be pulsed for intensity modulation.
LATCH DATA INPUTS (A, B, C, D)	3, 2, 13, 12	Data on these inputs are entered into the latches when the enable input is low. The binary weights of these inputs are A = 1, B = 2, C = 4, D = 8.
DECIMAL POINT CATHODES	4, 10	These LEDs are not connected to the logic chip. If a decimal point is used, an external resistor or other current-limiting mechanism must be connected in series with it.
LED SUPPLY	1	This connection permits the user to save on regulated VCC current by using a separate LED supply, or it may be externally connected to the logic supply (VCC).
LOGIC SUPPLY (VCC)	14	Separate VCC connection for the logic chip.
COMMON GROUND	7	This is the negative terminal for all logic and LED currents except for the decimal points.

The LED driver outputs are designed to maintain a relatively constant on-level current of approximately five milliamperes through each of the LED's forming the hexadecimal character. This current is virtually independent of the LED supply voltage within the recommended operating conditions. Drive current varies with changes in logic supply voltage resulting in a change in luminous intensity as shown in Figure 2. The decimal point anodes are connected to the LED supply; the cathodes are connected to external pins. Since there is no current limiting built into the decimal point circuits, this must be provided externally if the decimal points are used.

The resultant displays for the values of the binary data in the latches are as shown below.

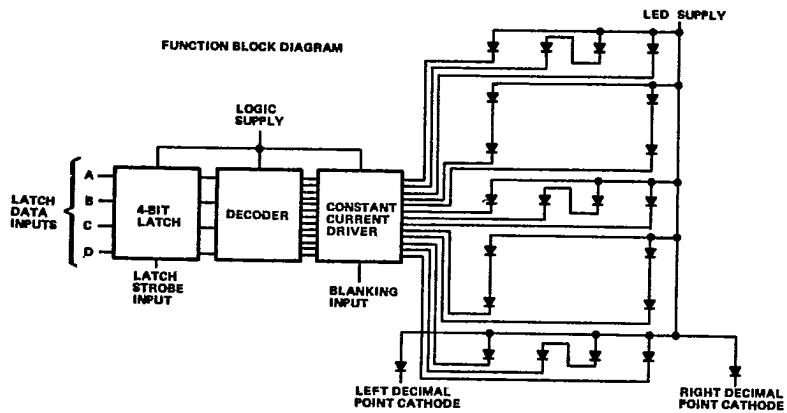
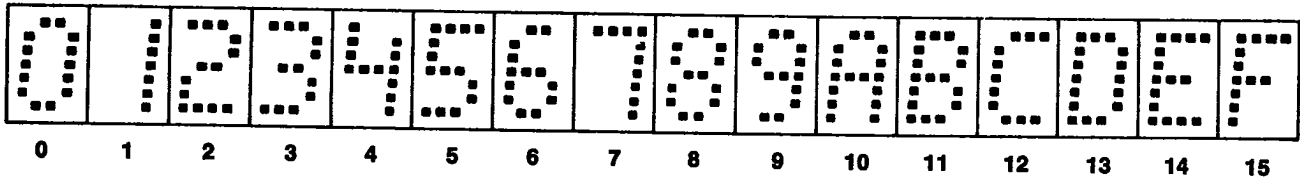

description 745-0007

absolute maximum ratings over operating ambient-air temperature range (unless otherwise noted)

Logic Supply Voltage, V_{CC} (See Note 1)	7V
LED Supply Voltage (See Note 1)	7V
Input Voltage (Pins 2, 3, 5, 8, 12, 13; See Note 1)	5.5V
Decimal Point Current	20 mA
Operating Ambient-Air Temperature Range	0°C to 70°C
Storage Temperature Range	-55°C to 100°C

NOTE 1: Voltage values are with respect to common ground terminal.

recommended operating conditions

	MIN	NOM	MAX	UNIT
Logic Supply Voltage, V_{CC}	4.5	5	6.5	V
LED Supply Voltage, V_{LED}	4	5	7	V
Decimal Point Current, $I_{F(DP)}$		5		mA
Latch Strobe Pulse Width, t_w	40			ns
Setup Time, t_{setup} (See Note 2)	50			ns
Hold Time, t_{hold} (See Note 3)	40			ns

NOTES: 2. Setup time is the interval immediately preceding the positive going transition of the latch strobe input during which interval the data to be displayed must be maintained at the latch data inputs to ensure its recognition.
 3. Hold time is the interval immediately following the positive-going transition of the latch strobe input during which interval the data to be displayed must be maintained at the latch data inputs to ensure its continued recognition.

operating characteristics at 25°C ambient-air temperature

PARAMETER		TEST CONDITIONS	MIN	TYP	MAX	UNIT
I_v Luminous Intensity (See Note 4)	Average Per Character LED	$V_{CC} = 5V, V_{LED} = 5V$ See Note 5	35	100		μcd
	Each decimal	$I_{F(DP)} = 5 mA$	35	100		μcd
λ_p Wavelength at Peak Emission		$V_{CC} = 5V, V_{LED} = 5V$ $I_{F(DP)} = 5 mA$, See Note 6	640	660	680	nm
B Spectral Bandwidth between Half-Power Points				20		nm
V_{IH} High-Level Input Voltage			2			V
V_{IL} Low-Level Input Voltage				0.8		V
V_I Input Clamp Voltage		$V_{CC} = 4.75V, I_I = -12 mA$		-1.5		V
I_I Input Current at Maximum Input Voltage		$V_{CC} = 5.5V, V_I = 5.5V$		1		mA
I_{IH} High-Level Input Current		$V_{CC} = 5.5V, V_I = 2.4V$		40		μA
I_{IL} Low-Level Input Current		$V_{CC} = 5.5V, V_I = 0.4V$		-1.6		mA
I_{CC} Logic Supply Current		$V_{CC} = 5.5V, V_{LED} = 5.5V,$ $I_{F(DP)} = 5 mA$, All inputs at OV	80	90		mA
I_{LED} LED Supply Current			45	90		mA

NOTES: 4. Luminous intensity is measured with a solar cell and filter combination which approximates the CIE (International Commission on Illumination) eye-response curve.
 5. This parameter is measured with A displayed, then again with E displayed.
 6. These parameters are measured with B displayed.

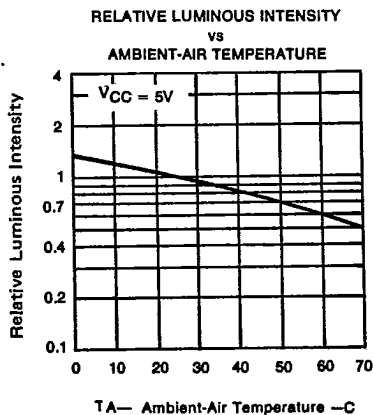

FIGURE 1

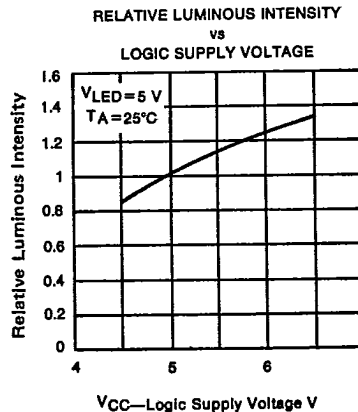

FIGURE 2